

Load Washers

for Forces of 7,5 ... 400 kN

Type 9001A ... 9071A

1-component force sensor for measuring dynamic and quasi-static forces in z direction.

- Very compact
- Extremely high rigidity
- Threshold <0,01 N, independent of measuring range

Description

The force to be measured acts through the cover and base of the tightly welded steel housing on the quartz sensing elements. Quartz yields an electric charge proportional to the mechanical load.

The sensitivity (a material constant of quartz) and therefore the threshold, too, are practically the same for all load washers.

This has three unique advantages:

- even very small forces can be measured with a sensor having a large range, which assures a high safety against overload.
- similarly a sensor with a large range can be chosen when the highest possible rigidity (small deformation) is required.
- several sensors can be connected electrically in parallel to a single charge amplifier whose output signal corresponds to the sum of all forces acting.

Application

The load washers are very rigid and suitable above all for measuring highly dynamic forces. Their extreme rigidity changes the dynamic behavior of the measuring object into which they are built in very little.

Depending on the magnitude of the force it is possible to measure quasistatically over several minutes or even hours. Zero point stability is substantially determined by charge amplifiers connected downstream. However, genuine static measurements over an infinitely long time are not possible.

Yet a sensor that has been loaded (e. g. inserted in a screwed connection) can, after any period of time, be connected again to a charge amplifier and the disappearance of the force can be measured again precisely.

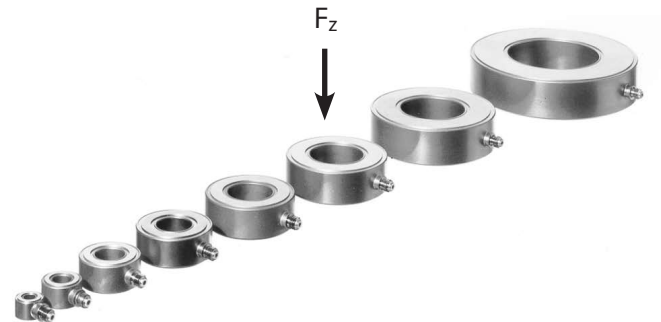

Dynamic measurements, however (AC-mode, peak-to-peak) can be done for an unlimited period of time. The load washers have a virtually unlimited life.

Application Examples

- Forces in assembly technology
- Forces in spot welding
- Forces in presses
- Force variations in bolted connections under high static pre-load
- Shock and fatigue resistance
- Cutting and forming forces
- Forces in railroad brakes
- Impact forces

Technical Data

Type*		9001A	9011A	9021A	9031A	9041A	9051A	9061A	9071A
Measuring range	kN	0 ... 7,5	0 ... 15	0 ... 35	0 ... 60	0 ... 90	0 ... 120	0 ... 200	0 ... 400
Calibrated ranges									
100 %	kN	0 ... 7,5	0 ... 15	0 ... 35	0 ... 60	0 ... 90	0 ... 120	0 ... 200	0 ... 400
10 %	kN	0 ... 0,75	0 ... 1,5	0 ... 3,5	0 ... 6	0 ... 9	0 ... 12	0 ... 20	0 ... 40
Overload	kN	9	18	42	72	108	144	240	480
Max. bending moment $M_{x,y}$ ***	N·m	$\leq \pm 5$	$\leq \pm 15$	$\leq \pm 60$	$\leq \pm 130$	$\leq \pm 240$	$\leq \pm 370$	$\leq \pm 830$	$\leq \pm 2\,500$
Rigidity	kN/ μ m	≈ 1	$\approx 1,8$	$\approx 3,5$	≈ 6	$\approx 7,5$	≈ 9	≈ 14	≈ 26
Capacity	pF	≈ 8	≈ 23	≈ 37	≈ 54	≈ 65	≈ 64	≈ 148	≈ 203
Dimensions									
Internal diameter d	mm	4,1	6,5	10,5	13	17	21	26,5	40,5
External diameter D	mm	10,3	14,5	22,5	28,5	34,5	40,5	52,5	75,5
Height H	mm	6,5	8	10	11	12	13	15	17
Weight	g	3	7	20	36	70	80	157	370

General Data

Sensitivity**	pC/N	$\approx -4,3$
Threshold	N	$\leq 0,01$
Operating temperature range	°C	-196 ... 200
Linearity typ., preloaded***	%FSO	$\pm 0,4$
Hysteresis typ., preloaded***	%FSO	0,2
Insulation resistance	Ω	$\geq 1 \cdot 10^{14}$
Temperature coefficient	%/°C	-0,02
Natural frequency		depends on additional mass

* further Types see data sheet quartz load washers (9081A_000-106)

** applies only to sensor **without** preloading nut (see page 3, mounting)

*** Preload $F_v = 0,5 \cdot$ measuring range $F_z = 0$

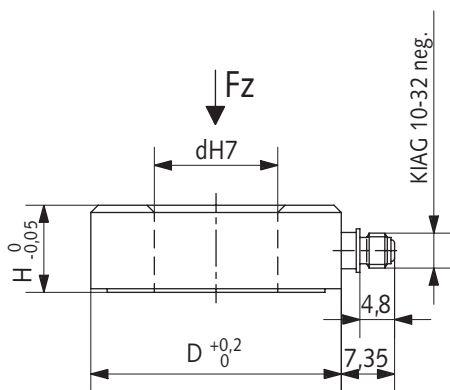

Fig. 1: Dimensions load washers

9001A_000-105e-08.07

Mounting

The load washers must be installed between two plane-parallel, rigid and fine-machined (preferably ground) faces. This is necessary to achieve a good load distribution on one hand and a wide frequency response on the other hand.

The load washers should always be installed under preload.

The reasons are:

- the sensor is fixed in this way
- measuring compression and tension
- the faces are pressed together which allows to benefit fully of the rigidity of the sensor

Important

For preloading, the force must always be measured with the sensor itself, using the sensitivity indicated in the technical data. The preloading screw always shunts part of the force and therefore the sensor must be calibrated again after installation to determine the final sensitivity of the completed measuring setup.

Simple Mounting with Mounting Set Type 9422A... (Included Accessories)

This mounting set is supplied with each sensor of Types 9001A ... 9051A. The sensor can be preloaded with the preloading screw up to 30 % of its range. The centering clip also serve to center the sensor with the screw (Fig. 2 and table).

The preloading screw shunts part of the force. Its sensitivity will be about 7 ... 9 % lower.

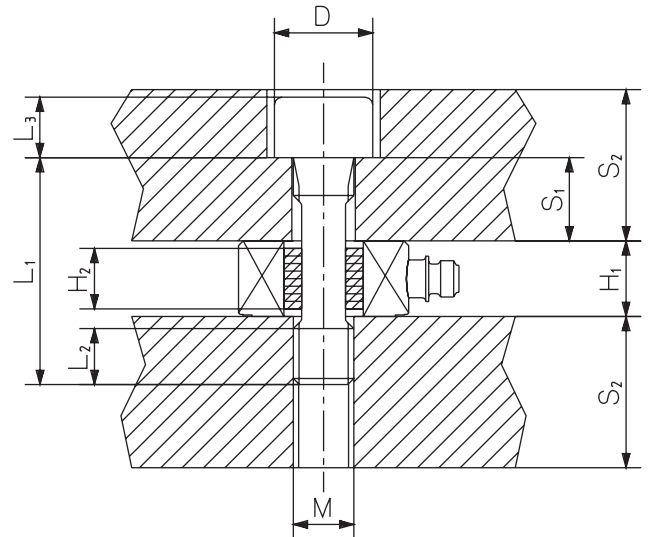

Fig. 2: Mounting with Type 9422A... (Included Accessories)

Sensor Type	Mounting Set Type	M	Dimensions								Preload Fp [kN]	Force Shunt %
			D	L ₁	L ₂	L ₃	H ₁	H ₂	S ₁	S ₂		
9001A	9422A01	M3x0,5	5,5	16	4,2	3,5	6,5	6	3,5	7	1,5 ... 2,5	≈7
9011A	9422A11	M5x0,8	8,5	20	6,5	6	8	6	4	10	3 ... 5	≈8
9021A	9422A21	M8x1,25	13	30	10	9	10	8	7	16	7 ... 10	≈9
9031A	9422A31	M10x1,5	16	35	12	11	11	8	9	20	12 ... 20	≈9
9041A	9422A41	M12x1,75	18	40	14,3	13	12	8	12	25	18 ... 30	≈9
9051A	9422A51	M14x2	21	45	16,6	15	13	9	15	30	24 ... 40	≈9

9001A_000-105e-08.07

Mounting with Preloading Elements Type 9420A...

Sets of special preloading elements for sensors Types 9001A ... 9071A are available (Fig. 3 and table). With these preloading stud bolts made of high-strength steel, the sensor can be preloaded up to 50 % of its range. At the same time they assure an optimal force introduction.

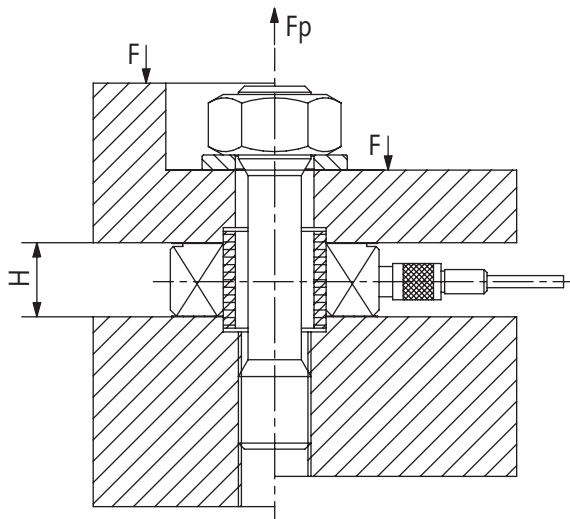

Fig. 3: Load washer preloaded with the preload set Type 9420A01 ... 9420A71 (see data sheet set of preloading elements for load washers 9420A_000-192)

Force Distributing Ring

Bearing surfaces must be flat and rigid. If they can not be fine machined, local overloads and damage to the sensor surfaces must be prevented by using a force distributing ring (Fig. 4).

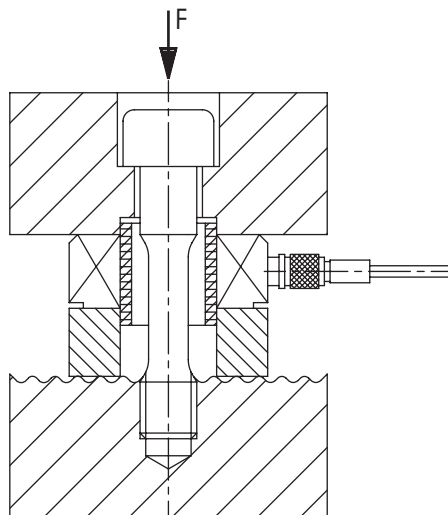

Fig. 4: Mounting with use of a force distributing ring Type 9505 ... 9575 (see data sheet mounting accessories for load washers Type 9505_000-193)

Force Links

The load washers Types 9001A ... 9071A are available already mounted and calibrated in the form of force links (see data sheet force links 9301B_000-107). They are ideal for measuring compression and tensile forces (Fig. 5).



Fig. 5: Force links Type 9301B ... 9371B

Connecting Quartz Sensors in Parallel

As all load washers have the same nominal sensitivity, several of them can be connected in parallel to a single charge amplifier. The output signal then corresponds to the sum of all forces acting on the connected sensors.

Included Accessories

- Load washer
- Special grease
- Mounting set

Optional Accessories

- Set of preloading elements:
Data sheet set of preloading elements for load washers (9420A_000-192)
- Mounting accessories:
Data sheet mounting accessories for load washers (9505_000-193)
- Connecting and extension cables:
Data sheet cables for force, torque and strain sensors (1631C_000-346)

9001A_000-105e-08.07

Ordering Key

Load Washer

Range 0 ... 0,75 kN	01
Range 0 ... 15 kN	11
Range 0 ... 35 kN	21
Range 0 ... 60 kN	31
Range 0 ... 90 kN	41
Range 0 ... 120 kN	51
Range 0 ... 200 kN	61
Range 0 ... 400 kN	71

Type 90 A

