

FORCE SENSOR WITH INTEGRATED ELECTRONICS

Piezoelectric force sensor with integrated charge amplifier electronics for measuring and monitoring dynamic and quasistatic force components in industrial process measuring technology etc. in

- Metalworking machines
- Presses
- Forming machines
- Automatic assembly machines
- Transfer lines

- 1 or 3 force component versions
- Rugged, sealed case for use in harsh industrial environments (IP67 and IP68)
- Integrated charge amplifier electronics
- 2 electrically switched measuring ranges
- Available with plug-in or integrated cables
- Case optionally with straight or right-angled cable or plug outlet
- Various accessories

The sensor is suitable for indirect force measurements (force shunt mode) as well as for direct measurements in the main force flux. The force sensor produces an amplified, low-impedance force-proportional voltage signal which can be directly processed by machine control systems, for example. The sensor connection is made via a multipole cable which can be a plug-in or integrated type.



Type 9602... is supplied **uncalibrated**. For accurate measurement (absolute value), the sensor must be calibrated in situ after installation.

Technical Data

Measuring axes		F_z	F_x, F_y
Measuring ranges			
Range I	kN	-5,0 ... 5,0	-2,5 ... 2,5
Range II	N	-1000 ... 1000	-500 ... 500
Preloading	kN	25	–
Overload	%	20	20
Sensitivity (nominal)			
Range I	mV/N	≈1	≈2
Range II	mV/N	≈5	≈10
Linearity	%FSO	≤±1,5	
Hysteresis	%FSO	≤1,5	
Crosstalk			
$F_z \rightarrow F_x, F_y$	%	≈±3	
$F_x \leftrightarrow F_y$	%	≈±5	
$F_x, F_y \rightarrow F_z$	%	≈±3	
Rigidity			
C_z	N/μm	1250	
C_x, C_y	N/μm	240	
max. moment load (without simultaneous shear force load)			
M_z	Nm	-18/18	
M_x, M_y	Nm	-14/14	
Supply			
Voltage	V DC	11...30	
Current (1 channel)	mA	≈7	
Current (3 channel)	mA	≈11	
Output			
Voltage	V	±5	
Resistance	Ω	≈100	

Noise (0 ... 1 kHz)	mV _{pp}	<2	
Offset	mV	<15	
Time constant standard	s	long	
Drift 0 ... 20 °C (typical)			
Range I (pC/s <0,03)	mV/s	F_z 0,008	F_x, F_y 0,02
Range II (pC/s <0,03)	mV/s	0,04	0,1
Reset time	ms	<1	
Reset Operate jump			
Range I (pC <2)	mV	<0,5	<1,25
Range II (pC <2)	mV	<2,5	<6,5
Control signal: Operate			
Reset	Input open or	V DC	0 ... 1
Operate		V DC	3 ... 30
Control signal: Range			
Range I	Input open or	V DC	6 ... 30
Range II		V DC	0 ... 1
Operating temperature range			
Temperatur (min/max)	° C	0 ... 60	
Vibration resistance			
(20 ... 200 Hz, cycle of 2 min, total 16 min)	g_{peak}	10	
Shock resistance (1 ms)	g	200	
Degree of protection (plug connection)	EN60529	IP67	
protection (integr. cable)	EN60529	IP68	
Cable protection		PUR	
Weight (sensor only)	g	≈30	

All information is the best representation of actual knowledge. All data is subject to change. Kistler does not assume any liability arising out of the application or use of any product or circuit described herein.

Block schematic diagram

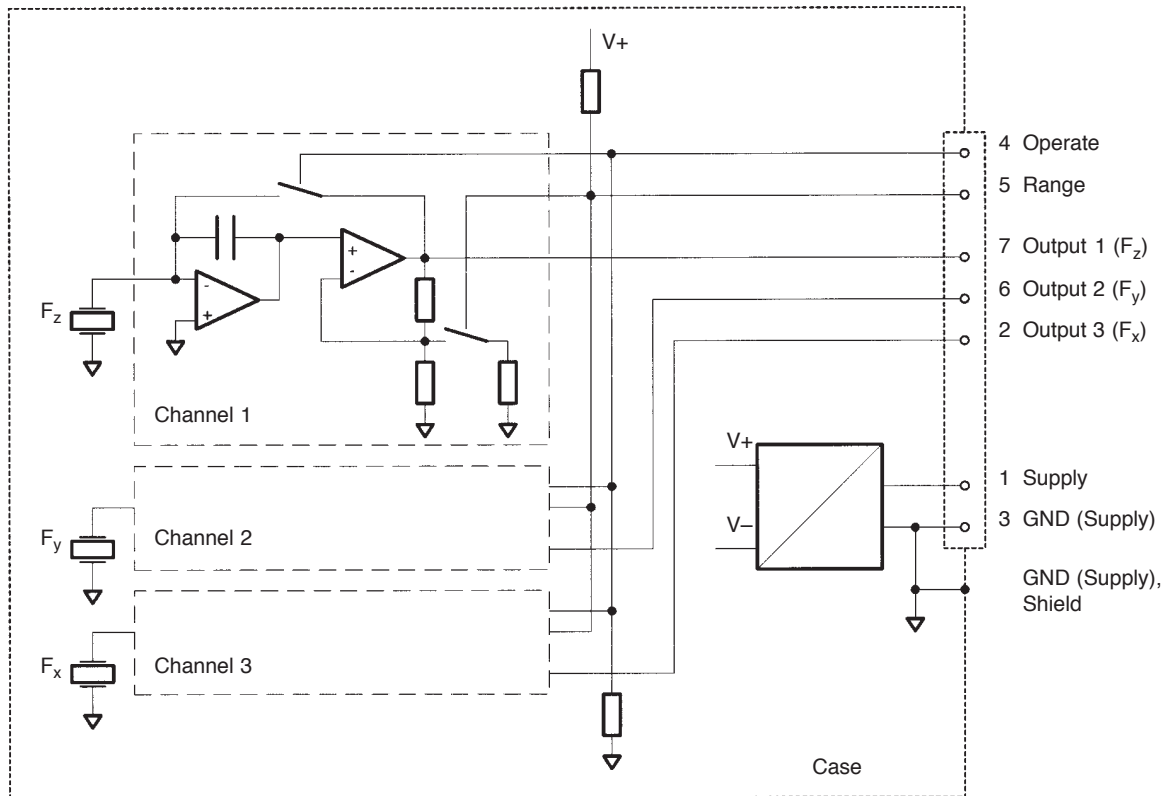

Accessories

- Preloading key Type 9463
- Connecting cable (to sensor with plug connection)
Fischer SE102Z, ohne cable end unconnected
Type 1783A5, l=5 m
Type 1783Asp, special length (on request)
- Preloading disk with screw Type 9408
- Preloading set Type 9461

Sensor connector pin allocations

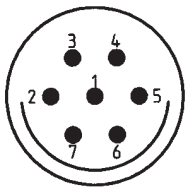

Pin	Color (open cable end)	Function
1	red	Supply
2	blue	Output 3 (F_x)
3	black	GND (signal)
4	green	Operate
5	orange	Range
6	gray	Output 2 (F_y)
7	white	Output 1 (F_z)
Screen		GND (Supply)

Sensor connection

For better interference signal rejection, we recommend the use of one differential amplifier per channel.

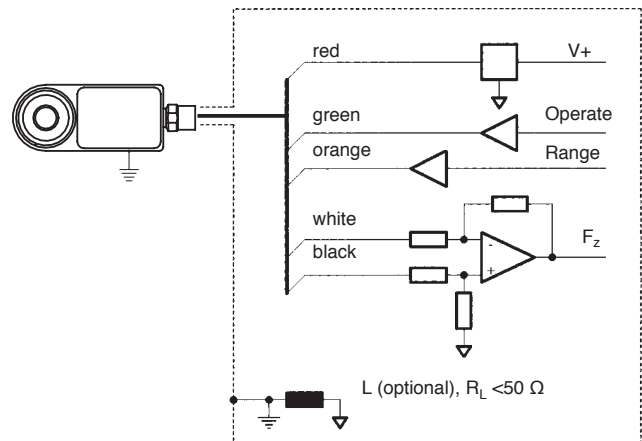

Electrical isolation can be achieved with one isolation amplifier per channel, two optocouplers for the control signals (Operate, Range) and an electrically isolated supply.

Dimensions

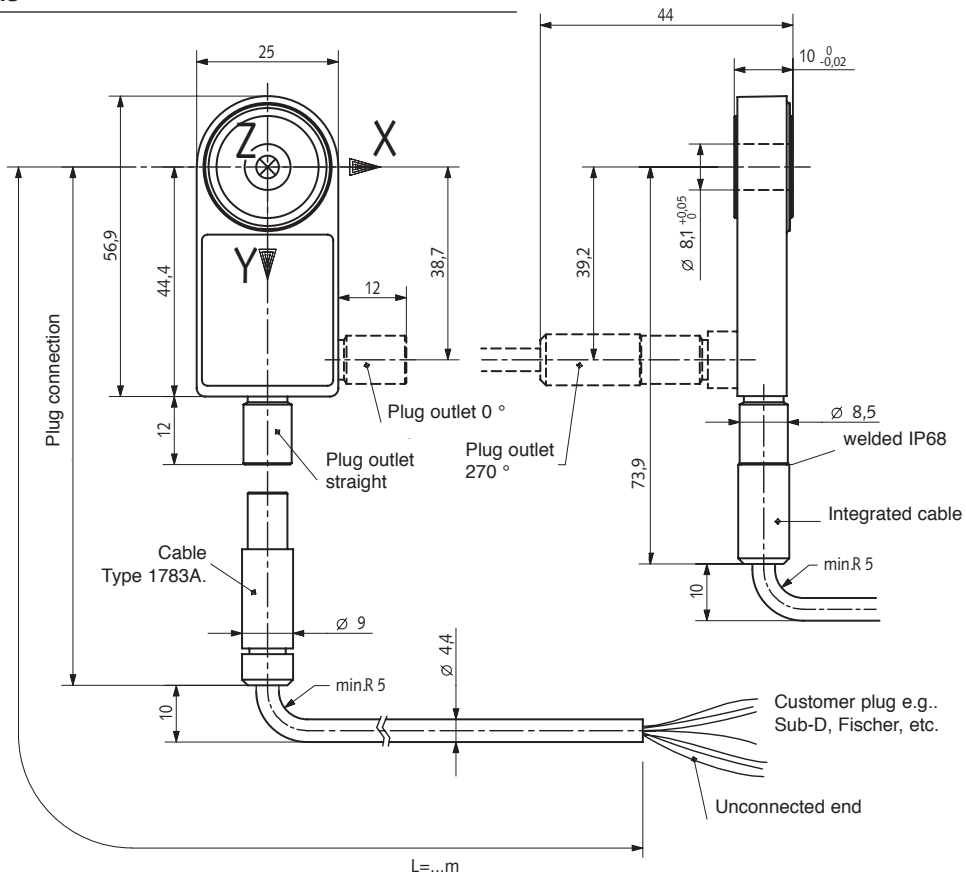

Mounting examples

Mounting (with preloading disk) between upper and lower parts of the structure.

Fitting the sensor

1. Measure height H of the sensor
2. Measure depth T of the mounting bore.
3. Grind thickness S of the adaptation disk.
Select $S = (T-H) + 0,015/+0,010$, $S \geq 2$ mm
4. Preload the sensor by assembling the base and cover plates.

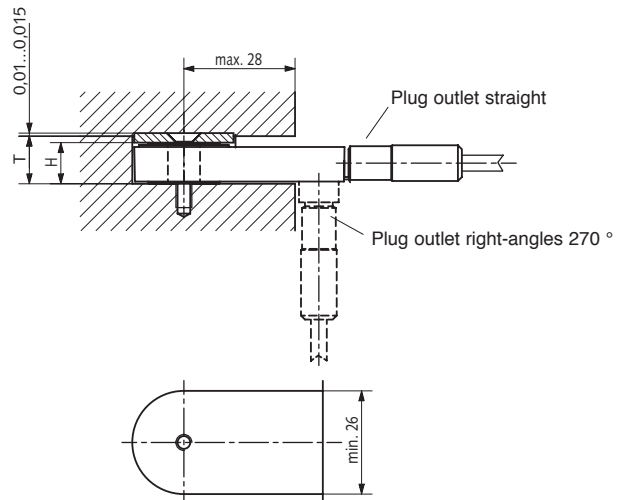
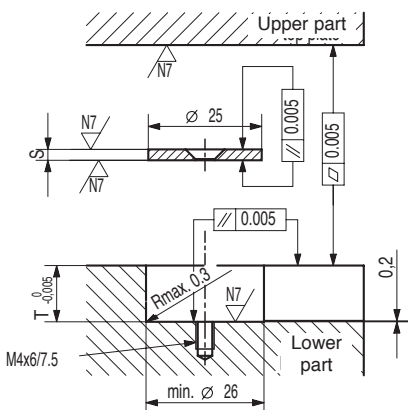

Mounting the sensor in machine structure with preloading disk
Type 9463

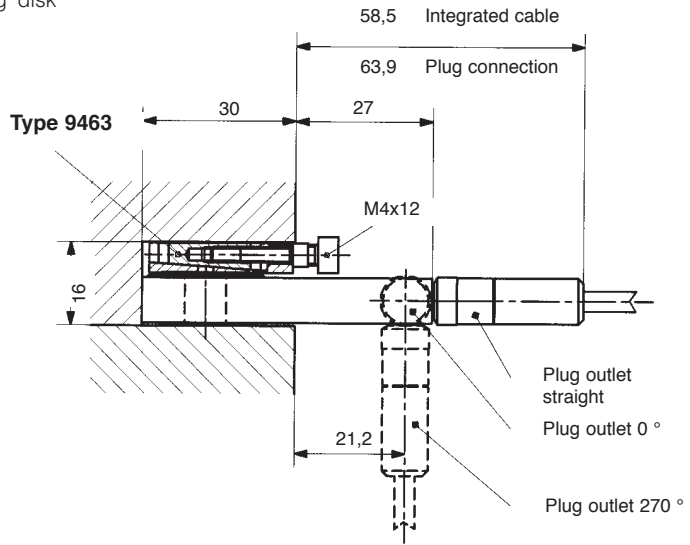
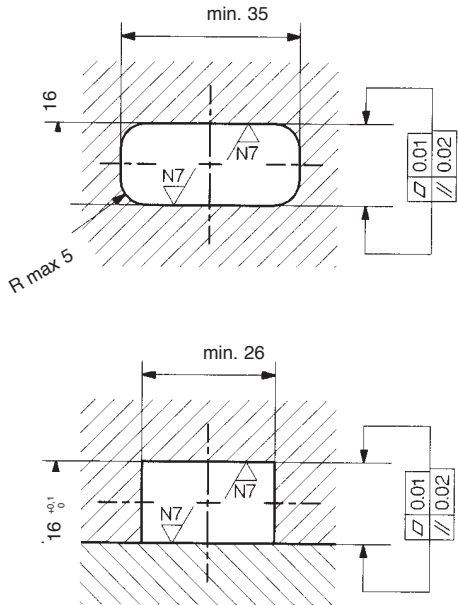

Fitting the sensor

1. Machine the mounting notch in the structure
2. Insert the sensor with preloading disk in the notch
3. Preload the sensor with the preloading disk

Mounting with preloading kit Type 9461 for direct force measurement

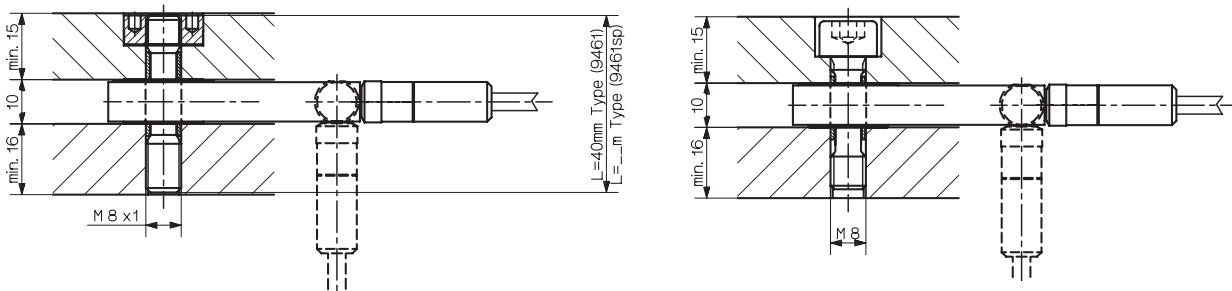

Ordering Code

Type 9602A

Measuring axes 1-comp. (F_z) 3-comp. ($F_x / F_y / F_z$)	1 3	
Sensor with plug connection with integrated cable	1 2	
Plug outlet at the sensor Straight Right-angles, 0° Right-angles, 270°	0 1 2	
Cable No cable (plug connection) Integrated, l = 5 m Integrated, special length	0 1 9	

All information is the best representation of actual knowledge. All data is subject to change. Kistler does not assume any liability arising out of the application or use of any product or circuit described herein.

Kistler Instrumente AG, Postfach, CH-8408 Winterthur
Tel + 41 - 52 - 224 11 11, Fax 224 14 14, sales@kistler.ch, www.kistler.com