

## 3-COMPONENT FORCE LINK $F_x, F_y, F_z$

Force link for measuring the three orthogonal components of a dynamic or quasistatic force acting in an arbitrary direction.

Very extended measuring range, high rigidity and minimal cross talk.

- Calibrated force link
- Simple installation

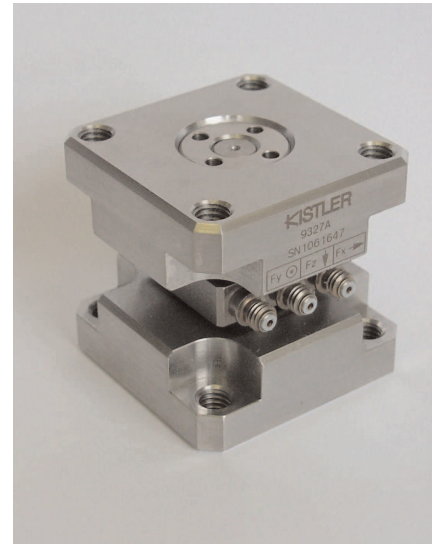
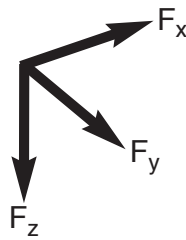

### Technical Data

|   |                                 |    |                         |
|---|---------------------------------|----|-------------------------|
| <b>Range</b><br><i>(Without moments if e.g. four force links are mounted into one force plate)</i>                | $F_x, F_y$                      | kN | -2,5 ... 2,5            |
| <b>Range</b><br><i>(Example with point of force application <math>F_{x,y}</math> 15 mm above top plate)</i>       | $F_x, F_y$                      | kN | -0,38 ... 0,38          |
| <b>Range</b><br><i>(Point of force application <math>F_z</math> centric)</i>                                      | $F_z$                           | kN | -5 ... 5                |
| <b>Overload</b>   |                                 | %  | 10                      |
| <b>Calibrated range</b><br><i>(Point of force application <math>F_{x,y}</math> 10 mm below top plate surface)</i> | $F_x, F_y$                      | kN | 0 ... 1,25; 0 ... 0,125 |
| <b>Calibrated range</b><br><i>(Point of force application <math>F_z</math> centric)</i>                           | $F_z$                           | kN | 0 ... 5; 0 ... 0,5      |
| <b>Max. moments</b>   | $M_{x,y}$<br>( $M_z=0; F_z=0$ ) | Nm | -14/14                  |
|   | $M_z$<br>( $M_{x,y}=0; F_z=0$ ) | Nm | -14/14                  |
|   |                                 | N  | <0,01                   |
| <b>Threshold</b>  |                                 | N  | <0,01                   |

|  |                            |       |                   |
|--|----------------------------|-------|-------------------|
| <b>Sensitivity</b>   | $F_x, F_y$                 | pC/N  | ≈ -7,9            |
|  | $F_z$                      | pC/N  | ≈ -3,8            |
| <b>Linearity,</b><br>each axis   |                            | % FSO | ≤±0,5             |
| <b>Hysteresis,</b><br>each axis  |                            | % FSO | ≤0,5              |
| <b>Cross talk</b><br><i>(Cross talk <math>F_x, F_y \rightarrow F_z</math> is ≤±3 % if e.g. four force links are mounted in to one force plate)</i> | $F_z \rightarrow F_x, F_y$ | %     | ≤±1               |
|  | $F_x \leftrightarrow F_y$  | %     | ≤±3               |
|  | $F_x, F_y \rightarrow F_z$ | %     | ≤±4               |
| <b>Natural frequency</b>   | $f_0(x)$                   | kHz   | ≈3,3              |
|  | $f_0(y)$                   | kHz   | ≈3,3              |
|  | $f_0(z)$                   | kHz   | ≈11,5             |
| <b>Operating temperature range</b>   |                            | °C    | -50 ... 80        |
| <b>Insulation resistance</b>   |                            | Ω     | ≥10 <sup>13</sup> |
| <b>Ground insulation</b>   |                            | Ω     | >10 <sup>8</sup>  |
| <b>Capacitance,</b><br>each channel  |                            | pF    | ≈30               |
| <b>Connector</b>   |                            |       | 3x10-32 neg.      |
| <b>Weight</b>  |                            | kg    | 0,39              |

000-167e-06.01 (DB06.9327e)

## Description

The force sensor is mounted under preload between two plates and, therefore can measure compression and tensile forces. The quartz element yields an electric charge which is proportional to the force. This is picked off by electrodes and transferred via a connector. The charge signal is fed via a screened cable to a charge amplifier, which converts it into a proportional output voltage. An appropriate evaluation circuit can record and further process the measurand.

The sensor is mounted ground-isolated. This largely eliminates ground loop problems.

## Types 9327A and 9328A

The force links Types 9327A and 9328A differ only in the position of the coordinate system relative to the sensor case (see Fig. 1).

The technical data of both types are identical. When combining the Types 9327A and 9328A in a force plate with four force links, the position of the coordinate system relative to the connectors can be chosen as desired (see also Fig. 2).

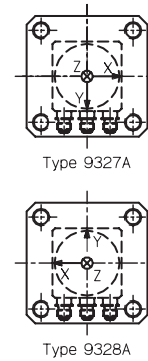

Fig. 1

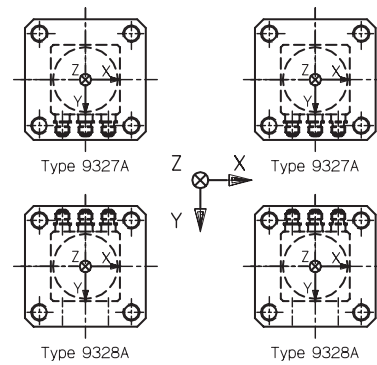
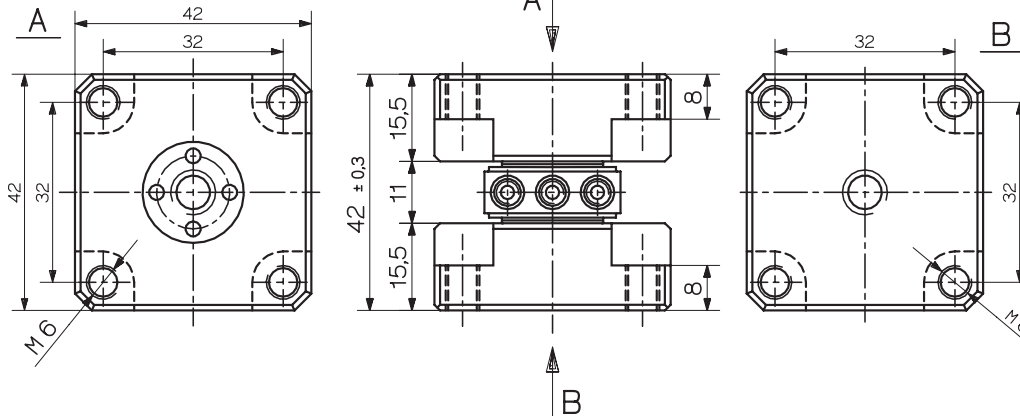

Fig. 2

## Dimensions

Fig. 3



## Mounting

The contact surfaces that transfer the forces onto the force link must be flat, rigid and clean.

When four force links are used to construct a force plate, they must be machined to the same level.

The force links can be fastened either from outside with four screws M6 in each case or from the center again in each case with four screws M5.

The screws must be tightened sufficiently so that even with maximum force exerted, no gap occurs between the contact surfaces.

## Force introduction

When only a single force link is used, then as far as possible, the center of pressure should be within the cover plate.

Eccentric force introduction produces a moment of force on the sensor element and is permitted only up to specified values. If such a moment prevails, then the areas of force must be reduced accordingly.

A rigidly constructed force plate with four force links largely prevents moment stresses on the sensor element.

000-167e-06.01 (DB06.9327e)

## Mounting examples

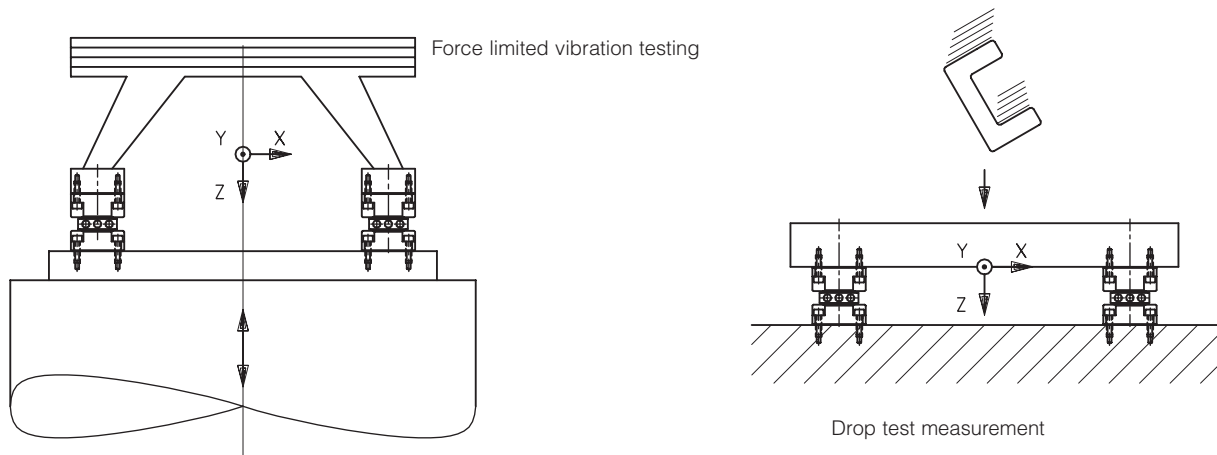

## Application

The force links can measure the 3 orthogonal force components easily, directly and precisely, because these sensors feature an inherently low cross talk.

The elastic behaviour of the test object is practically not influenced. Quasistatic measurements, are possible, too. **The force link is supplied calibrated.** After correct installation, it is immediately ready for use without re-calibration.

Thanks to their high rigidity they cover a wide frequency range.

## Application examples

- Cutting forces
- Impact forces
- Dynamic forces on shakers
- Determination of coefficients of friction

## Available versions

### Type 9327A

3-Component Force link with standard coordinate system (see Fig. 1)

### Type 9328A

3-Component Force link like Type 9327A, but with coordinate system rotated 180° about z-axis (see Fig. 1)

## Accessories

- Connecting cable  
see data sheet 15.011

## Parallel Switching

Several force links of identical sensitivities can be paralleled directly. The charge amplifier connected then gives an output voltage which corresponds to the sum of all forces acting.

This is a great advantage when building force plates with which only the 3 components of the resulting force must be measured.

## Electronics

Besides the force sensors, a 3-component force measuring system also requires 3 charge amplifiers, which convert the electrical charge signals of the sensor into voltages exactly proportional to the three components  $F_x$ ,  $F_y$  and  $F_z$  of the acting force.

In order to construct multicomponent force plates for measuring three forces and three moments, special multichannel charge amplifiers are available.