

Miniature Longitudinal Measuring Pin M5 Type 9247A...

for Indirect Measurement of Forces in Machinery and Tools

Piezoelectric sensor for monitoring forces and strains in machines and tools. This extreme compact, longitudinally sensitive pin is used for indirect measurement of dynamic and quasistatic forces. It is particularly suitable for sensing very large forces where installation space is limited.

- Extreme compact installation size
- Indirect measurement of very large forces
- Preloaded mounting allows measurement of compressive and tensile forces
- Can be mounted at virtually any depth in the structure

Description

The measuring pin is mounted with a precisely defined preload. The strain in the surrounding material is transferred via the end of the sensor and the external thread to the quartz sensing element.

The electrical charge output is proportional to the change in mechanical strain. A charge amplifier converts the charge into a voltage signal that can be processed as required.

After being mounted in the structure as prescribed, the strain sensor must be calibrated by comparison measurement against a force calibration sensor, for example.

Application

The sensor could easily be mounted with a installation wrench and allows measurement of the forces within a machine component or tool. It is used mainly for industrial monitoring of machinery forces (machine and tool monitoring), e.g. in sheet metal forming (installation in the ram of mechanical presses), connection techniques (monitoring of forces in screws), jointing techniques (quality control of blind riveting), plastic injection molding machines (monitoring of forces in molds) and assembly techniques (measurement of forces in clamping devices).

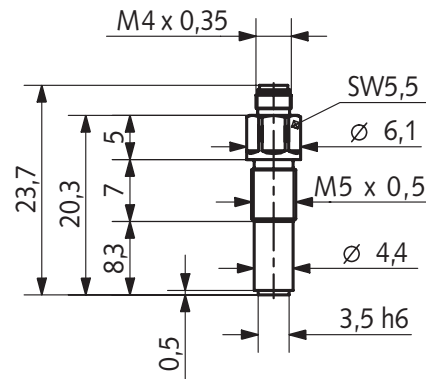

Technical Data

Range ¹⁾	με	-1 400 ... 1 400
Overload	με	±2 000
Axial preloading force	kN	≈3,3 (≈-20 000 pC)
Sensitivity (in test object)	pC/με	≈-8,6
Sensitivity to force (for preload)	pC/N	≈-6
Reproducibility of sensitivity when dismounting and remounting	%	<±1
Linearity	%FSO	≤±1
Hysteresis	%FSO	≤2
Natural frequency	kHz	>200
Acceleration sensitivity	pC/g	<0,07
Operating temperature range	°C	-40 ... 200
Insulation resistance at 20 °C	Ω	≥10 ¹³
Degree of protection (with connected cable)		IP65
Weight (without cable and preloading bolt)	g	2,5
Connection		M4x0,35 neg.

¹⁾ Sensor mounted with preload

Installation

Provide mounting bore as in Fig. 1. The front contact surface ($\varnothing 4,5$ mm) for the sensor must be clean and machined flat. Apply a **thin film of grease** to the front face of the sensor Technical Data ($\varnothing 3,5$ mm) and also to the M5 thread.

Connect the sensor to a charge amplifier (e.g. Preload Tester Type 5991) and carefully preload with socket wrench Type 1300A9 until it produces the prescribed charge of $-20\ 000$ pC.

Fig. 2 shows an installation example.

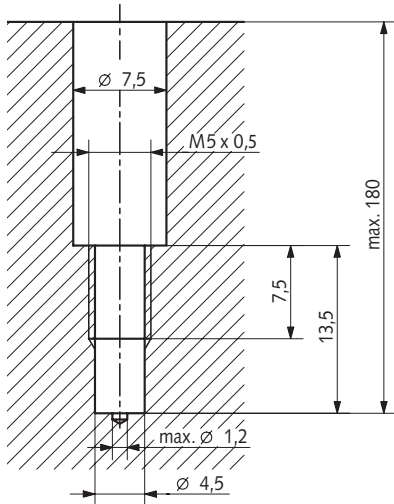

Fig. 1: Mounting bore

Installation Example

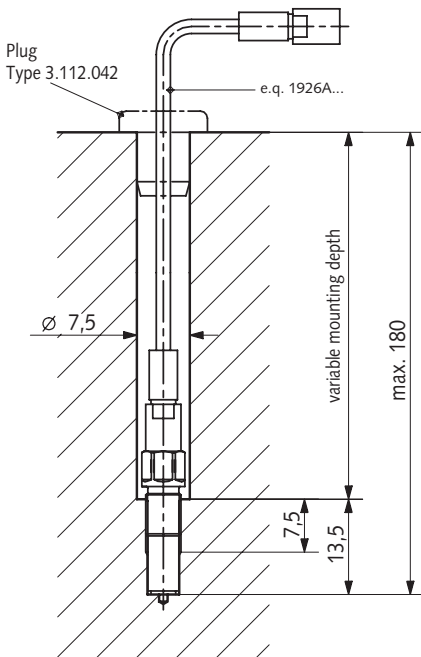

Fig. 2: Installation example longitudinal measuring pin type 9247A...

Couplings

Type 1700A31



M4 neg./KIAG 10-32 pos.

Type 1700A23



M4 neg./M4 neg.

Type 1700A13



M4 neg./KIAG 10-32 neg.

Type 1724A1

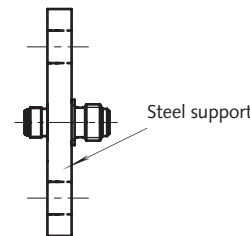

M4 neg./KIAG 10-32 neg.

Type 1724A2

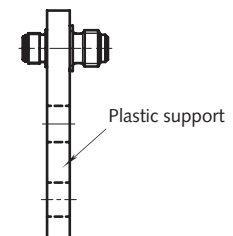

M4 neg./KIAG 10-32 neg.

Type 1705

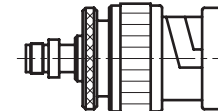

M4 neg./BNC pos.

Type 1700A33

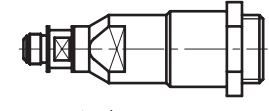

M4 neg./Fischer KE102A014-16 neg.

Fig. 3: Couplings for longitudinal measuring pin Type 9247A...

Example of an Industrial Measuring Chain

Measuring chain consisting of:

- Longitudinal measuring pin Type 9247A...
- Connecting cable Type 1926Asp0,1-2
- Connector coupling Type 1700A31
- In-Line Amp charge amplifier Type 5027A... (see Data sheet 5027A_000-299)

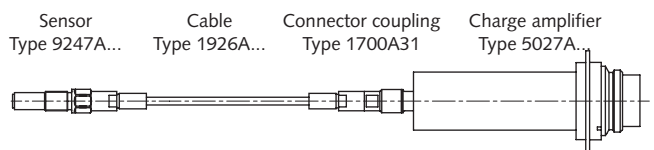

Fig. 4: Example of an industrial measuring chain

9247A_000-143e-12.06

Example of Calculation (estimation of sensitivity)

Exercise

A steel cylinder with a cross-sectional area of 1 134 mm² (≈∅ 38 mm) is loaded with a compression force F of 300 kN. A quartz longitudinal measuring pin M5 Type 9247A is installed in its axis.

How high is its force sensitivity?

Solution

$$\sigma \text{ [N/mm}^2\text{]} = \frac{F}{A} = \frac{300\,000 \text{ N}}{1\,134 \text{ mm}^2} = 265 \text{ N/mm}^2$$

$$E \text{ [N/mm}^2\text{]} = \text{Modulus of elasticity of steel} = 200\,000 \text{ N/mm}^2$$

$$e \text{ [}\mu\epsilon\text{]} = \frac{\Delta l}{l_0} = \frac{\sigma}{E} = \frac{265 \text{ N/mm}^2}{200\,000 \text{ N/mm}^2} = 1,32 \cdot 10^{-3} \text{ m/m} = 1\,320 \mu\epsilon$$

$$1 \text{ [}\mu\epsilon\text{]} = 1 \mu\text{m/m} = 10^{-6} \text{ Strain } (\Delta l/l_0)$$

Check

Is the calculated strain e within the measuring range?
→ Yes, the measuring range is (see Technical Data) = ±1 400 με

Calculation of the force sensitivity of the built-in sensor

$$S_e = \text{Sensitivity of the sensor (see Technical Data)} = -8,6 \text{ pC}/\mu\epsilon$$

$$Q = e \cdot S_e = 1\,320 \mu\text{m/m} \cdot (-8,6 \text{ pC}/\mu\epsilon) = -11\,352 \text{ pC}$$

$$S_F = \frac{Q}{F} = \frac{-11\,352 \text{ pC}}{300\,000 \text{ N}} = -0,0378 \text{ pC/N} = \underline{\underline{-37,8 \text{ pC/kN}}}$$

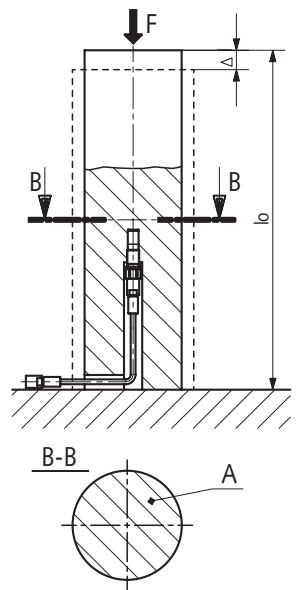

Legend

Symbol	Meaning	Unit
F	Axial force	N
A	Cross-sectional area at the mounting point.	mm ²
σ	Average mechanical stress at the mounting point	N/mm ²
E	Modulus of elasticity of the structural material	N/mm ²
e	Strain	μϵ
l ₀	Length of the unloaded cylinder	m
Δl	Change in length due to load F	m
S _e	Strain sensitivity of the sensor	pC/μϵ
Q	Electric charge	pC
S _F	Force sensitivity of the built-in sensor for forces acting in the cylinder axis	pC/N

Note

This calculation produces an approximation. The exact force sensitivity of the built-in sensor can only be determined by direct calibration on the object measured.

9247A_000-143e-12.06

Accessories Included

- none

Type/Art. No.

Ordering Key

Type 9247A

Optional Accessories

Tools for installation

- Tubular socket wrench
SW internal 5,5/external 7,3 mm,
wrench length 220 mm
- Special typ M5x0,5
- Finishing tool for bore,
bore depth ≤60 mm
- Finishing tool for bore,
bore depth ≤170 mm
- Preload tester
- Hand-held charge amplifier

Sensor without cable	–
Sensor with connecting cable Type 1926A0,8 (l = 0,8 m)	0,8
Sensor with connecting cable Type 1926Asp, cable length with order (L _{min.} = 0,1 m/L _{max.} = 10 m)	sp

Connecting cable

- PFA, ø 2 mm, M4 pos. int./
M4 pos. int., length 0,8 m
- PFA, ø 2 mm, M4 pos. int./
M4 pos. int., Length 0,1 ... 2 m
- PFA, ø 2 mm, M4 pos. int./
M4 pos. int., special length
- Metal tubing, ø 2,6 mm,
M4 pos. int./M4 pos. int.,
length 0,5 m
- Metal tubing, ø 2,6 mm,
M4 pos. int./M4 pos. int.,
length 1 m
- Metal tubing, ø 2,6 mm,
M4 pos. int./M4 pos. int.,
special length

Plug

- Plastic, ø 7,5 mm

Dimensions Miniature Longitudinal Measuring Pin Type 9247A0,8

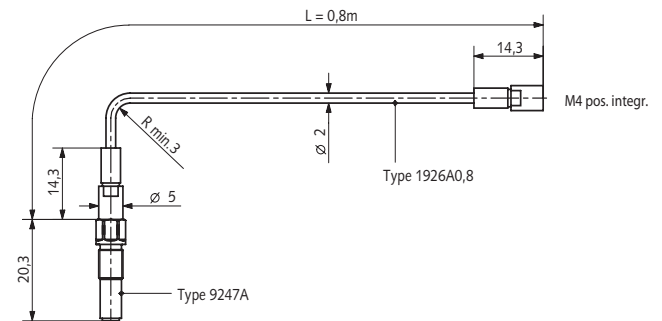

Fig. 5: Type 9247A0,8