

Load Washers

for Forces of 7,5 ... 1 200 kN

Type 9001A ... 9071A
9081B, 9091B

1-component force sensor for measuring dynamic and quasi-static forces in z direction.

- Very compact
- Extremely high rigidity
- Threshold $<0,01$ N (for Type 9001A ... 9071A) and $\leq 0,02$ N (for Type 9081B, 9091B), independent of measuring range

Description

The force to be measured acts through the cover and base of the tightly welded steel housing on the quartz sensing elements. Quartz yields an electric charge proportional to the mechanical load.

The sensitivity (a material constant of quartz) and therefore the threshold, too, are practically the same for all load washers.

This has three unique advantages:

- even very small forces can be measured with a sensor having a large range, which assures a high safety against overload.
- similarly a sensor with a large range can be chosen when the highest possible rigidity (small deformation) is required.
- several sensors can be connected electrically in parallel to a single charge amplifier whose output signal corresponds to the sum of all forces acting.

Application

The load washers are very rigid and suitable above all for measuring highly dynamic forces. Their extreme rigidity changes the dynamic behavior of the measuring object into which they are built in very little.

Depending on the magnitude of the force it is possible to measure quasistatically over several minutes or even hours. Zero point stability is substantially determined by charge amplifiers connected downstream. However, genuine static measurements over an infinitely long time are not possible.

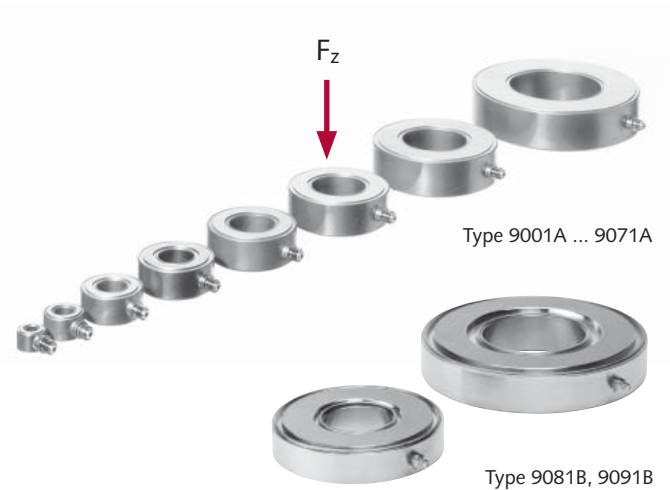

Yet a sensor that has been loaded (e. g. inserted in a screwed connection) can, after any period of time, be connected again to a charge amplifier and the disappearance of the force can be measured again precisely.

Dynamic measurements, however (AC-mode, peak-to-peak) can be done for an unlimited period of time. The load washers have a virtually unlimited life.

Application Examples

- Forces in assembly technology
- Forces in spot welding
- Forces in presses
- Force variations in bolted connections under high static pre-load
- Shock and fatigue resistance
- Cutting and forming forces
- Forces in railroad brakes
- Impact forces

Technical Data

Type ¹⁾		9001A	9011A	9021A	9031A	9041A	9051A	9061A	9071A
Measuring range	kN	0 ... 7,5	0 ... 15	0 ... 35	0 ... 60	0 ... 90	0 ... 120	0 ... 200	0 ... 400
Calibrated ranges									
100 %	kN	0 ... 7,5	0 ... 15	0 ... 35	0 ... 60	0 ... 90	0 ... 120	0 ... 200	0 ... 400
10 %	kN	0 ... 0,75	0 ... 1,5	0 ... 3,5	0 ... 6	0 ... 9	0 ... 12	0 ... 20	0 ... 40
Overload	kN	9	18	42	72	108	144	240	480
Max. bending moment $M_{x,y}$ ²⁾	N·m	5	15	60	130	240	390	800	2 400
Rigidity	kN/μm	≈1	≈1,8	≈3,5	≈6	≈7,5	≈9	≈14	≈26
Capacity	pF	≈8	≈23	≈37	≈54	≈65	≈64	≈148	≈203
Dimensions									
Internal diameter d	mm	4,1	6,5	10,5	13	17	21	26,5	40,5
External diameter D	mm	10,3	14,5	22,5	28,5	34,5	40,5	52,5	75,5
Height H	mm	6,5	8	10	11	12	13	15	17
Weight	g	3	7	20	36	70	80	157	370

General Data

Sensitivity ³⁾	pC/N	≈-4,3							
Threshold	N	≤0,01							
Operating temperature range	°C	-196 ... 200							
Linearity typ., preloaded ³⁾	%FSO	≤±1 (±0,3)							
Hysteresis typ., preloaded ³⁾	%FSO	≤0,5 (0,1)							
Insulation resistance	Ω	≥1·10 ¹⁴							
Temperature coefficient	%/°C	-0,02							
Natural frequency ⁵⁾	kHz	65	65	65	65	62	55	48	30
Degree of protection EN60529									
with connected cable	IP	65							
with cable Type 1983AD... and welded sensor	IP	67							

- 1) Preload $F_v = 0,5 \cdot$ measuring range; $F_z = 0$
- 2) applies only to sensor **without** preloading nut (see page 4, mounting)
- 3) applies for installation with mounting kit Type 9422A... or preloading kit Type 9420A...
- 4) applies for installation with mounting kit Type 9455/56
- 5) in a dismounted condition (not preloaded) the natural frequency will be reduced due to the installation conditions

9001A_000-105e-09.10

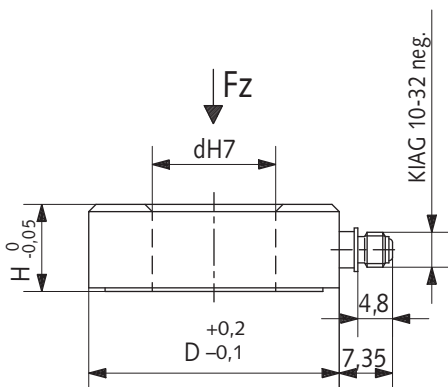

Fig. 1: Dimensions load washer, Type 9001A ... 9031A

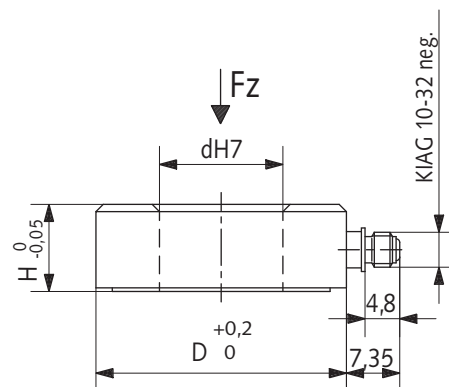

Fig. 2: Dimensions load washer, Type 9041A ... 9071A

Type		9081B	9091B
Measuring range	kN	0 ... 650	0 ... 1 200
Calibrated ranges			
100 %	kN	0 ... 650	0 ... 1 200
10 %	kN	0 ... 65	0 ... 120
Overload	kN	715	1 320
Max. bending moment $M_{x,y}$ ¹⁾	N·m	4 430	13 260
Rigidity	kN/ μ m	30	65
Capacity	pF	≈750	≈890
Dimensions			
Internal diameter d	mm	40,5	72
External diameter D	mm	100	145
Height H	mm	22	28
Weight	g	910	2 180

General Data

Sensitivity ²⁾	pC/N	≈-2,2
Threshold	N	≤0,02
Operating temperature range	°C	-40 ... 200
Linearity typ., preloaded ⁴⁾	%FSO	≤±0,6 (±0,2)
Hysteresis typ., preloaded ⁴⁾	%FSO	≤0,2 (0,15)
Insulation resistance	Ω	≥5·10 ¹³
Temperature coefficient	%/°C	-0,02
Natural frequency ⁵⁾	kHz	>18 >11
Degree of protection EN60529	IP	65
with connected cable		
with cable Type 1983AD...	IP	67
and welded sensor		

- 1) Preload $F_v = 0,5 \cdot$ measuring range; $F_z = 0$
- 2) applies only to sensor **without** preloading nut (see page 4, mounting)
- 3) applies for installation with mounting kit Type 9422A... or preloading kit Type 9420A...
- 4) applies for installation with mounting kit Type 9455/56
- 5) in a dismounted condition (not preloaded) the natural frequency will be reduced due to the installation conditions

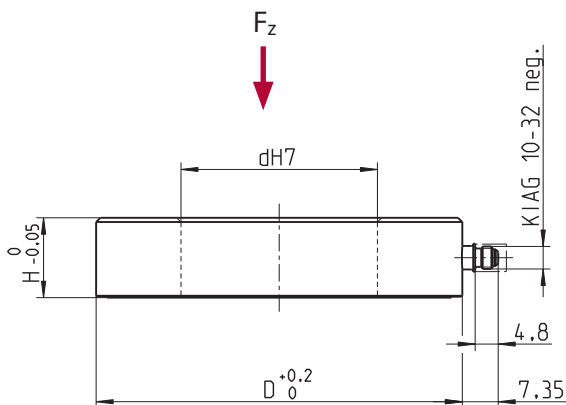

Fig. 3: Dimensions load washer, Type 9081B and 9091B

9001A_000-105e-09.10

Mounting

The load washers must be installed between two plane-parallel, rigid and fine-machined (preferably ground) faces. This is necessary to achieve a good load distribution on one hand and a wide frequency response on the other hand.

The load washers should always be installed under preload.

The reasons are:

- the sensor is fixed in this way
- measuring compression and tension
- the faces are pressed together which allows to benefit fully of the rigidity of the sensor

Simple Mounting with Mounting Set Type 9422A... (Included Accessories)

This mounting set is supplied with each sensor of Types 9001A ... 9051A. The sensor can be preloaded with the preloading screw up to 30 % of its range. The centering clip also serve to center the sensor with the screw (Fig. 4 and table).

The preloading screw shunts part of the force. Its sensitivity will be about 7 ... 9 % lower.

Important

For preloading, the force must always be measured with the sensor itself, using the sensitivity indicated in the technical data. The preloading screw always shunts part of the force and therefore the sensor must be calibrated again after installation to determine the final sensitivity of the completed measuring setup.

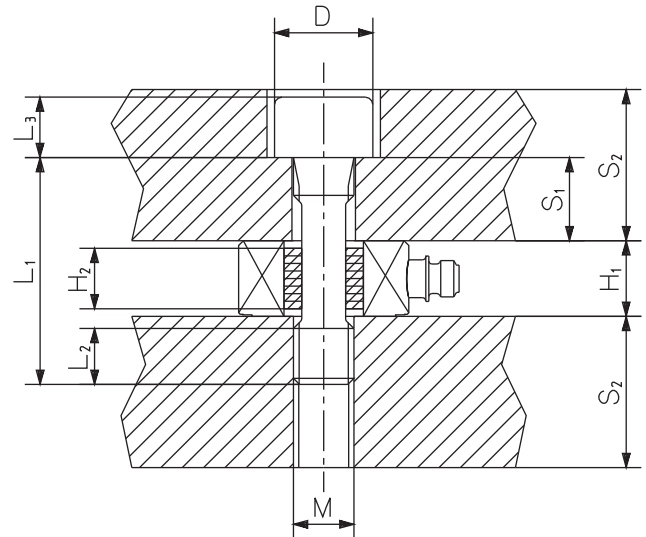

Fig. 4: Mounting with Type 9422A... (Included Accessories)

Sensor Type	Mounting Set Type	M	Dimensions								Preload F_y [kN]	Force Shunt %
			D	L ₁	L ₂	L ₃	H ₁	H ₂	S ₁	S ₂		
9001A	9422A01	M3x0,5	5,5	16	4,2	3,5	6,5	6	3,5	7	≤2,5	≈7
9011A	9422A11	M5x0,8	8,5	20	6,5	6	8	6	4	10	≤5	≈8
9021A	9422A21	M8x1,25	13	30	10	9	10	8	7	16	≤10	≈9
9031A	9422A31	M10x1,5	16	35	12	11	11	8	9	20	≤20	≈9
9041A	9422A41	M12x1,75	18	40	14,3	13	12	8	12	25	≤30	≈9
9051A	9422A51	M14x2	21	45	16,6	15	13	9	15	30	≤40	≈9

Mounting with Preloading Elements Type 9420A...

Sets of special preloading elements for sensors Types 9001A ... 9071A are available (Fig. 5). With these preloading stud bolts made of high-strength steel, the sensor can be preloaded up to 50 % of its range. At the same time they assure an optimal force introduction.

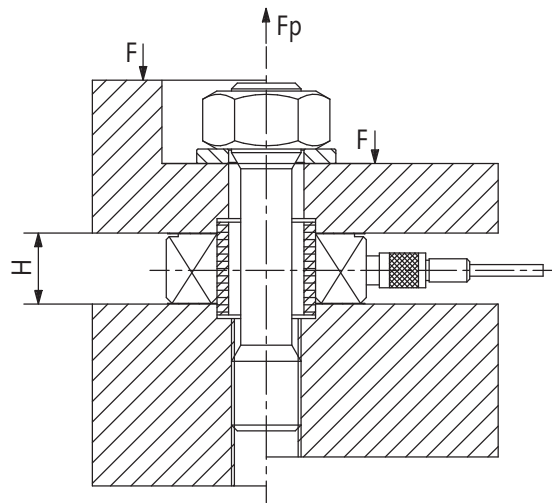

Fig. 5: Load washer preloaded with the preload set Type 9420A01 ... 9420A71 (available as accessories, see data sheet set of preloading elements for load washers 9420A_000-192)

Mounting with Preloading Elements Type 9455/56

With the preloading elements Types 9455 and 9456 (available as accessories) sensor Types 9081B and 9091B can be preloaded with a force of up to 400 kN / 600 kN. The high preload forces can only be applied hydraulically. The preloading as well as the calibration of the whole force link can be done at the Kistler headquarter in Winterthur, Switzerland if necessary.

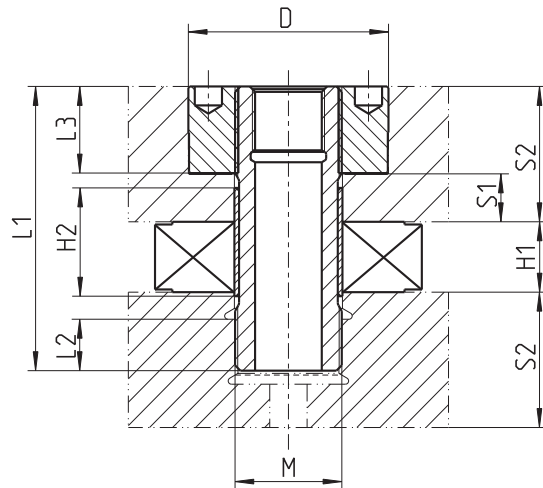

Fig. 6: Load washer preloaded with the preload set Type 9455/56 (available as accessories, see data sheet set of preloading elements for load washers 9455A_000-195)

Sensor Type	Mounting Set Type	M	Dimensions								Preload F_v [kN]	Force Shunt %
			D	L ₁	L ₂	L ₃	H ₁	H ₂	S ₁	S ₂		
9081B	9455	M40x2	75	105	20	33	22	40	19	50	≤250	≈9
9091B	9456	M64x3	120	140	28	36	28	53	23	70	≤450 (hydr.)	≈9

9001A_000-105e-09.10

Force Distributing Ring

Bearing surfaces must be flat and rigid. If they can not be fine machined, local overloads and damage to the sensor surfaces must be prevented by using a force distributing ring (Fig. 7).

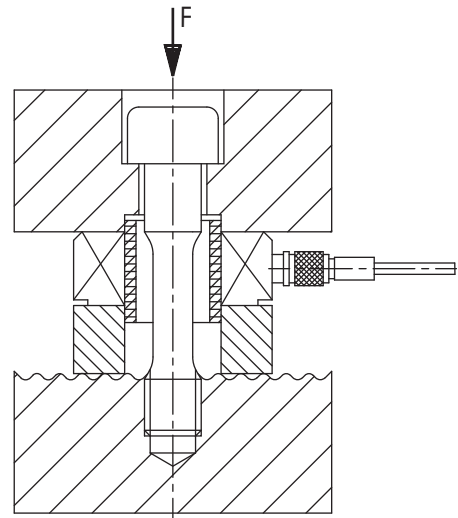

Fig. 7: Mounting with use of a force distributing ring Type 9505 ... 9575 (see data sheet mounting accessories for load washers Type 9505_000-193)

Bending Moment

Bending moments may not only have a negative influence on the measurement, but may even lead to destruction of the sensor. However, when the sensor is mounted in a thrust rod or a press punch, it is often impossible to avoid bending moments entirely.

The permissible value for the bending moment M_b is dependent on the sum of the preloading force F_v and the current process force F_z applied, in which the maximum possible bending moment $M_{b,max}$ is reached at $F_v+F_z = B/2$.

$$(1a) \quad M_{b,perm.} \leq \frac{2 \cdot M_{b,max}}{B} \cdot (F_v + F_z) \quad F_v + F_z \leq B/2$$

$$(1b) \quad M_{b,perm.} \leq \frac{2 \cdot M_{b,max}}{B} \cdot (B - F_v - F_z) \quad F_v + F_z \geq B/2$$

In the bending moment graph, the equations (1) limit the range of the permissible bending moment as a function of F_v and F_z .

Maximum Possible Bending Moment

Type	Range limit value B [kN]	Max. possible bending moment $M_{b,max}$ [N·m]
9001A...	7,5	5
9011A...	15	15
9021A...	35	60
9031A...	60	130
9041A...	90	240
9051A...	120	390
9061A...	200	800
9071A...	400	2 400

With the table values for B and $M_{b,max}$, the permissible pure bending moment as a function of the preload force F_v and the process force F_z can be estimated as follows:

Bending Moment Graph

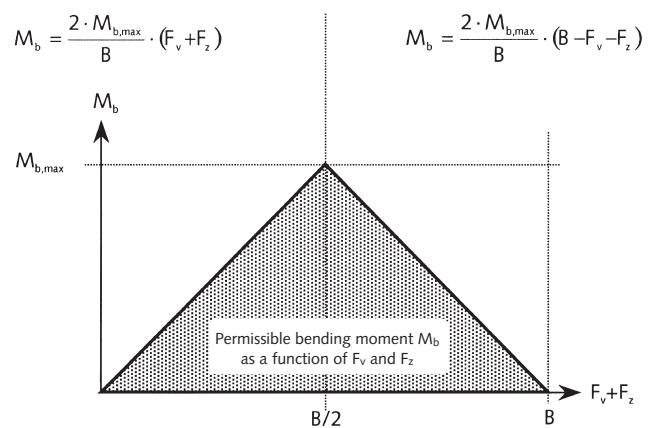

Fig. 8: Bending moment graph (pure bending moment)

9001A_000-105e-09.10

Attention

If a bending moment $M_b = F_{x,y} \cdot h$ is produced by a lateral force $F_{x,y}$ at a distance h from the reference plane, this will lead to a shear force $F_{x,y}$ in the sensor plane. In this case, the maximum permissible bending moment is lower than the permissible value for a pure bending moment determined using the equations (1).

Example 1

A SlimLine sensor Type 9031A is preloaded with 18 kN. What bending moment is acceptable for process forces in the range of 0 ... 40 kN?

$$F_v + F_{z,\min} = 18 + 0 = 18 \text{ kN} \leq B/2 \rightarrow (1a) \rightarrow M_b \leq 78 \text{ N}\cdot\text{m}$$

$$F_v + F_{z,\max} = 18 + 40 = 58 \text{ kN} \geq B/2 \rightarrow (1b) \rightarrow M_b \leq 8,67 \text{ N}\cdot\text{m}$$

The bending moment must not be greater than 8,67 N·m.

Example 2

A SlimLine sensor Type 9051A is preloaded with 30 kN. How wide is the measuring range with a bending moment of 35 N·m? By resolving (1) according to F_z , we get the equations (2) with which the permissible measuring range for the process force F_z can be calculated as a function of a bending moment.

$$(2a) \quad F_{z,\min} \geq \frac{B \cdot M_b}{2 \cdot M_{b,\max}} - F_v$$

$$(2b) \quad F_{z,\max} \leq B \cdot \left(1 - \frac{M_b}{2 \cdot M_{b,\max}}\right) - F_v$$

Inserting the values for B , $M_{b,\max}$ and F_v produces the permissible measuring range for F_z

from (2a) $-24,6 \text{ kN} \leq F_z \leq 84,62 \text{ kN}$ from (2b).

Attention

Lateral forces $F_{x,y}$ and/or a torque M_z further reduce the measuring range.

When the equations (2a) and (2b) are resolved according to F_v , the minimum preload force required or the maximum permissible preload force can be calculated as a function of the other parameters.

Mounting in Force Shunt Mode

The widest variety of measuring problems can be solved with the load washer mounted in force shunt mode. The mounting surface must be flat and be ground as finely as possible. The sensor can be center aligned at both the inner and outer sheaths. For mounting as in Fig. 6, the measuring surface of the sensor and the separation surface of the machine structure must be machined together. In all cases, the sensor must be machined only on one side to a maximum of 0,10 mm. Depending on applications, the sensor is preloaded from 10 % to 20 % of the measuring range. This is done by placing a steel foil (a few μm thick) on the measuring surface of the sensor (Fig. 6) or by preloading with a special nut (Fig. 7).

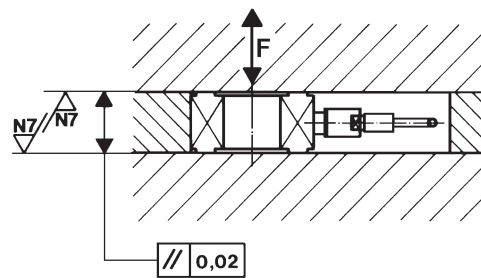

Fig. 9: Mounting for force shunt measuring

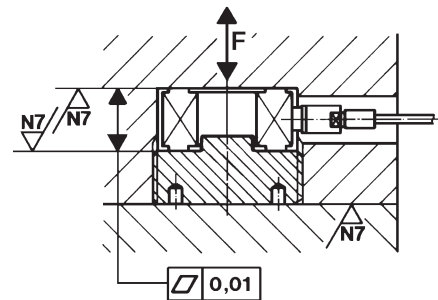

Fig. 10: Mounting in force shunt mode

Connection

Only high-insulation coaxial cables with low capacitance producing only very low triboelectricity during movement must be used for connecting piezoelectric sensors. For industrial environments, we recommend using the types listed in the Accessories. For more stringent requirements in a harsh environment, the industrial, integrated cable connector KIAG 10-32 with O-ring is used. If required, the connector can be seal welded to the sensor case.

9001A_000-105e-09-10

Connecting Cable for Sensors with KIAG 10-32 neg. Connector Type 1631C...

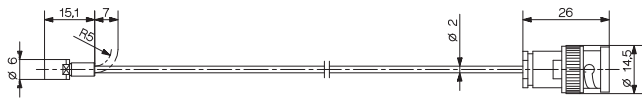

Connecting Cable for Sensors with KIAG 10-32 neg. Connector Type 1941A...



Connecting Cable for Sensors with KIAG 10-32 neg. Connector Type 1983AD...

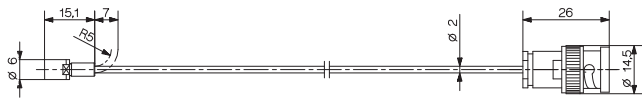

Please refer to data sheet 1631C_000-346 for further information on the cables.

Force Links

The load washers Types 9001A ... 9071A are available already mounted and calibrated in the form of force links (see data sheet force links 9301B_000-107). They are ideal for measuring compression and tensile forces (Fig. 5).



Fig. 11: Force links Type 9301B ... 9371B

Connecting Quartz Sensors in Parallel

As all load washers have the same nominal sensitivity, several of them can be connected in parallel to a single charge amplifier. The output signal then corresponds to the sum of all forces acting on the connected sensors.

Sensor Type 90x1A	Connecting Cable Type 1631C...	maXYmo Type 5867A...
------------------------------	---	---------------------------------



Sensor Type 90x1A	Connecting Cable Type 1631C...	Charge Amplifier Type 5015A...
------------------------------	---	---



Sensor Type 90x1A	Connecting Cable Type 1983AD	Charge Amplifier Type 5073A111
------------------------------	---	---



9001A_000-105e-09.10

Included Accessories

- Special grease Type/Art. No.
1063
- Mounting set 9422A...
(metric thread for
Types 9001A ... 9051A, inch thread
for Types 9001AU33 ... 9051AU33)
- Steckerschutz (Type 9081B/9091B) 3.414.366

Optional Accessories

- Set of preloading elements:
Data sheet set of preloading elements for load washers
(9420A_000-192)
- Mounting accessories:
Data sheet mounting accessories for load washers
(9505_000-193)
- Connecting and extension cables:
Data sheet cables for force, torque and strain sensors
(1631C_000-346)
- Set of preloading elements:
Data sheet set of preloading elements for force sensors
(9455_000-195)

Ordering Key

Load Washer

Range 0 ... 7,5 kN	01
Range 0 ... 15 kN	11
Range 0 ... 35 kN	21
Range 0 ... 60 kN	31
Range 0 ... 90 kN	41
Range 0 ... 120 kN	51
Range 0 ... 200 kN	61
Range 0 ... 400 kN	71

Load Washer

Range 0 ... 650 kN	81
Range 0 ... 1 200 kN	91

Type 90 A

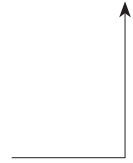

Type 90 B

