

# p-T-Sensor

## for Mold Cavity Pressure and Temperature

Type 6190A...

p-T-sensor for mold cavity pressure up to 2000 bar and contact temperature in the cavity when injection molding plastics. Design without diaphragm but with flat front.

- Suitable for industrial use
- Measures pressure and temperature

### Description

The p-T sensor Type 6190A... for mold cavity pressure and temperature has a front diameter of 4 mm.

The pressure acts over the entire front of the sensor and is transmitted to the quartz measuring element, which produces a proportional electric charge (pC = Picocolomb). This is converted into a voltage 0 ... 10 V in the amplifier and is then available as an amplifier output.

The contact temperature of the melt is measured on the front of the sensor by one pair of thermocouples, type K (NiCr-Ni). The sensor front can therefore not be machined.

This product complies with **CE** standard 89/336/EEC.

### Application

The p-T sensor measures the mold cavity pressure and the contact temperature of the injection molded part in the cavity. It is suitable for industrial application for monitoring, controlling and regulating the injection molding of thermoplastics, elastomers.

Caution! This sensor must never be used for gases or liquids!

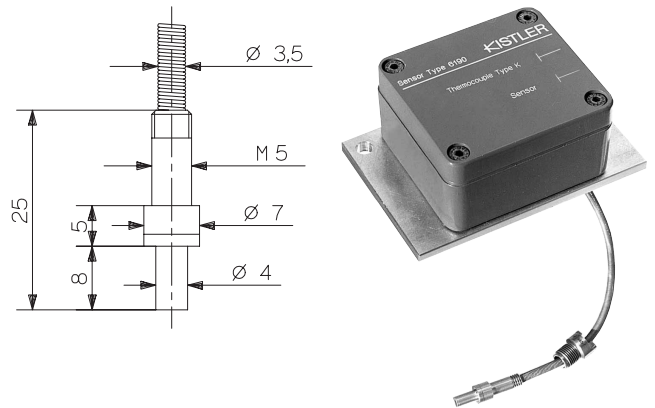

### Technical Data

Range	bar	0 ... 2 000
Overload	bar	2 500
Sensitivity	pC/bar	-2,5
Linearity, all ranges	%FSO	≤±1
Natural frequency	kHz	>80
Temperature coefficient of sensitivity (pressure)	%/°C	±0,01
Thermocouple, Type K		NiCr-Ni
Operating temperature range		
Mold (Sensor, cable, connector box)	°C	0 ... 200*
Melt (at the front of the sensor)	°C	<450
Insulation resistance		
at 20 °C	TΩ	100
at 200 °C	TΩ	1

\* During malfunctions of the machine the mold temperature may reach 240 °C without damaging the sensor. However there may be errors in the measurement.

**Measuring Chain with Sensor Type 6190A... and Machine-Integrated Charge Amplifier**

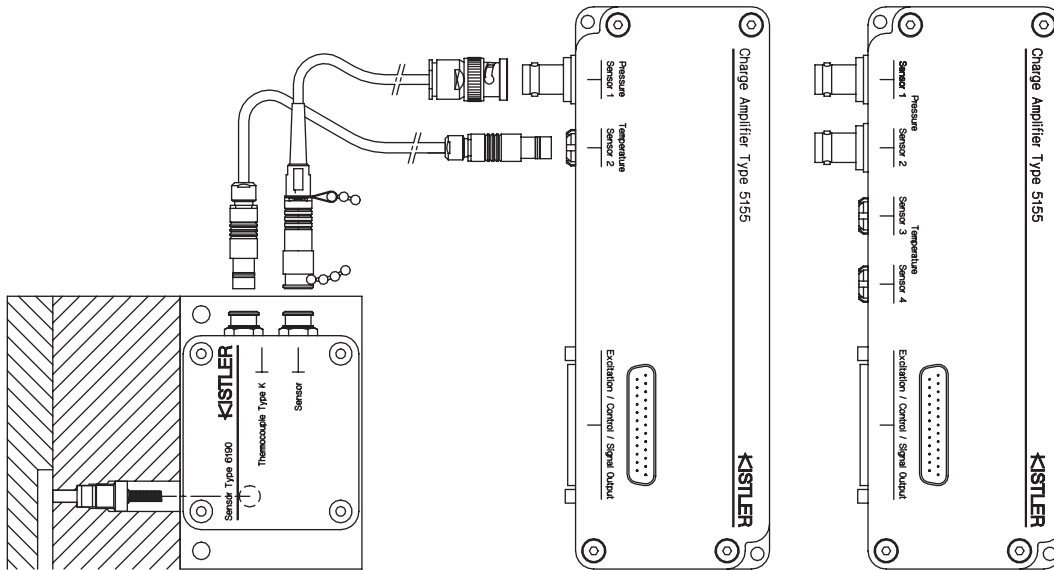

Cable Type 1667B... (BNC) & Type 2295A...	Cable Type 1672B... (TNC) & Type 2295A...
5155xxBx	5155xxAx
5155xxDx	5155xxCx

Fig. 1: Sensor Type 6190A... with charge amplifier Type 5155xxA (1- or 2-channel)

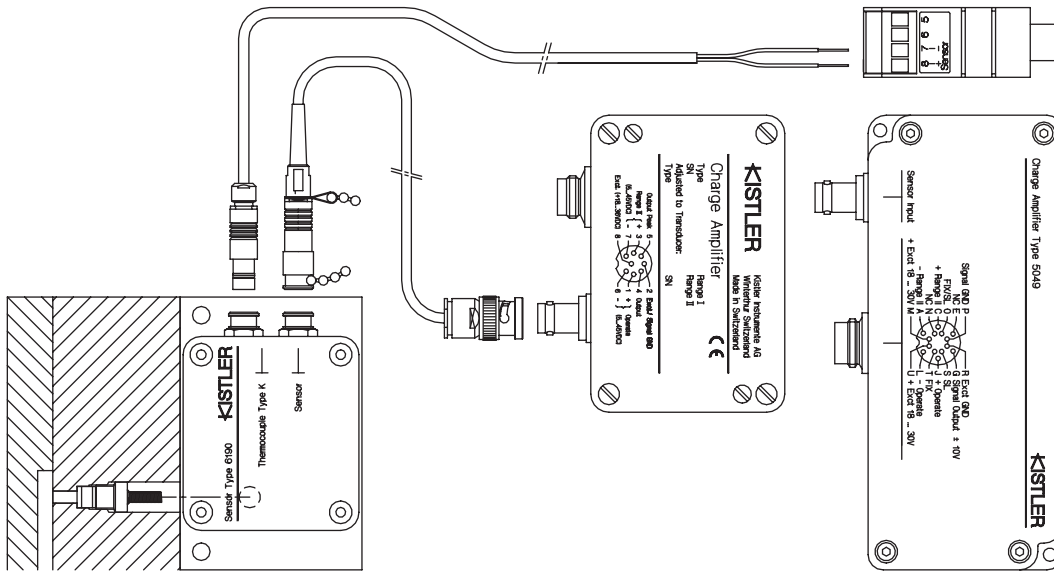

Cable Type 1667B... (BNC) & Type 2290A...	Cable Type 1672B... (TNC) & Type 2290A...
5039Axx2	5039Axx1
5049Axx2	5049Axx1

Fig. 2: Sensor Type 6190A... with charge amplifier Type 5039A... or Type 5049A... and temperature amplifier (eg. Type 2209A1)

6190A\_000-039e-10.04

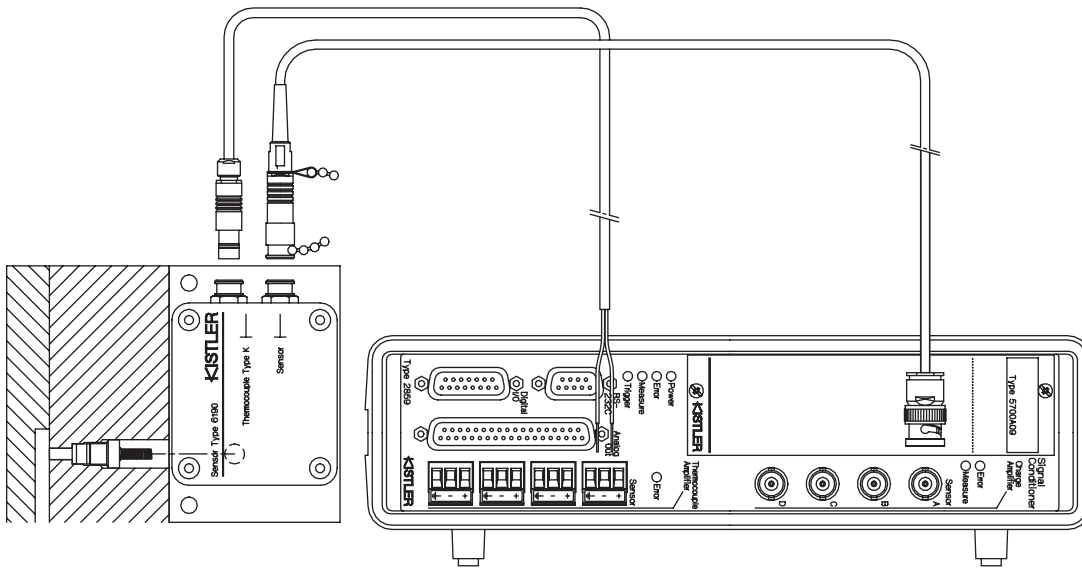

Cable Type 1667B... & Type 2290A...

PiCo Type 2859A...

Fig. 3: Sensor Type 6190A... with PiCo Signal Conditioner Type 2859A...

**Dimensions**

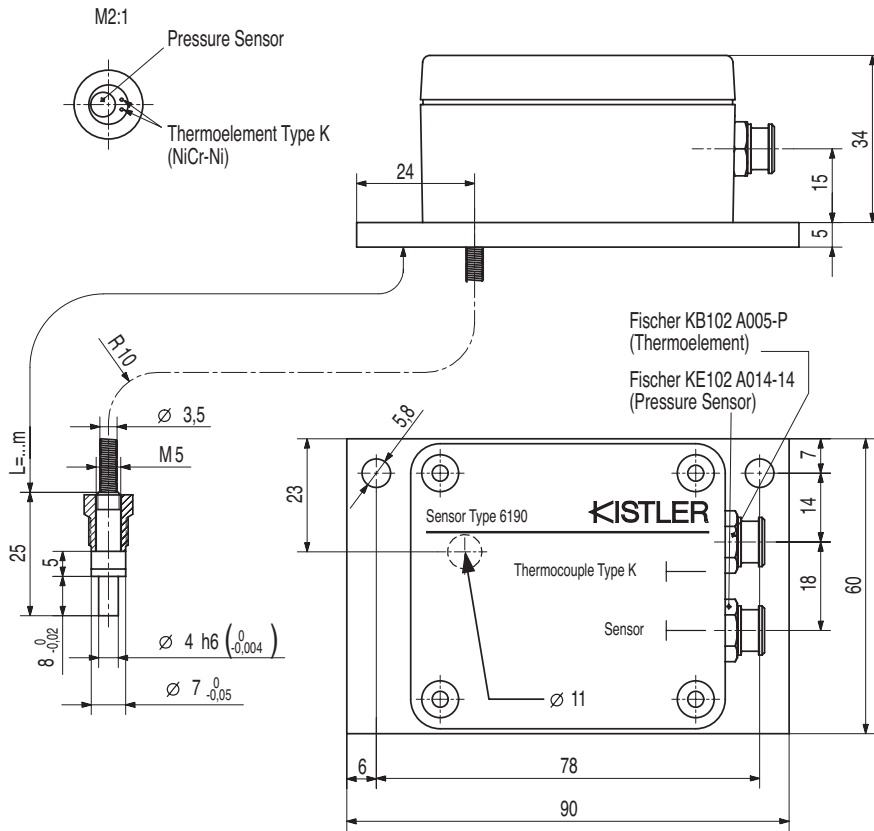

Fig. 4: Type 6190A...

**Installation Examples**

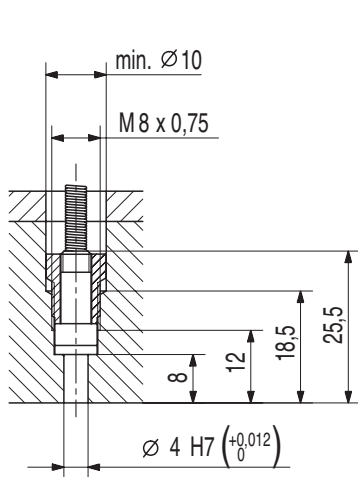

Fig. 5: Installation with mounting nut Typ 6457

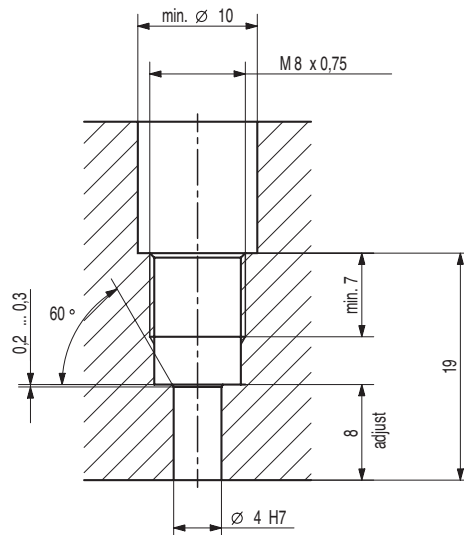

Fig. 6: Stepped hole

6190A\_000-039e-10.04

**Information about Thermocouples**

The response of a thermocouple depends on its mass. The smaller the mass, the faster the thermocouple will react to temperature fluctuations. In the case of the Type 6190A..., the individual thermocouple leads are fed separately to the sensor front thereby minimizing its mass. The actual thermocouple is produced by welding the two thermocouple leads to the sensor front. It should be pointed out in this respect, that it is not the mass temperature of the melt which is measured but the contact temperature on the surface of the molded part.

The thermocouple Type K that is used for this application is based on the technical advantages such as the corrosion resistance.

**Mounting**

The sensor is fitted with the mounting nut in the stepped hole.

Since the sensor forms part of the cavity wall, it must be fitted in such a way that its front is exactly flush. The sensor is centered in the diameter 4 H7 bore.

The housing must be mounted in a well-protected position on the mold.

Intermediate cable lengths (e.g. 0,6 m cable length) can be realised by retracting the excess cable length into the connection housing and securing it. An Allan key (2,5 mm) and a Phillips screw driver are required (see Fig. 8).

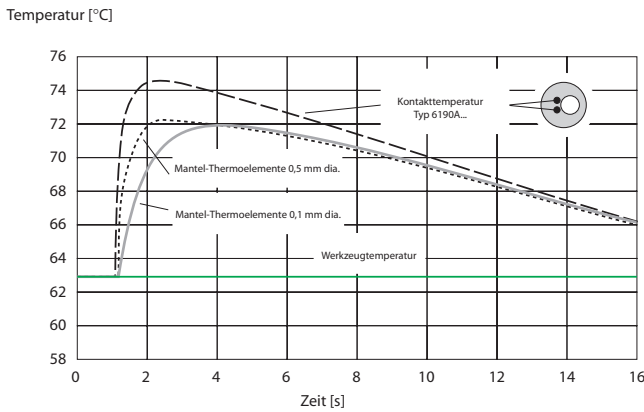

Fig. 7: Comparison with shell-type thermocouples

6190A\_000-039e-10.04

**Accessories Included**

- Mounting nut with slit
- Cap with chain
- Cylinder screw

<b>Art. No./Type</b>
6457
7.621.004
6.120.029

**Ordering Key**

Type 6190A

Cable length L in m	0,4
	0,8
	1,2
	1,6
2	
Special length, specify cable length L in m (L <sub>min</sub> = 2,0 m / L <sub>max</sub> = 3,5 m)	sp

**Optional Accessories**

- High-temperature extension cable (pressure)  
Fischer SE102 A014 – BNC pos.  
Length 2 m  
Length 5 m
- High-temperature extension cable (pressure)  
Fischer SE102 A014 – TNC pos.  
Length 2 m  
Length 5 m
- Compensation lead for Type 5155A.../2859...  
Length 2 m  
Length 5 m
- Compensation lead (Temperature) (open end)  
Length 2 m  
Length 5 m
- Dummy sensor
- Spacer sleeve

<b>Type</b>
1667B2
1667B5
1672B2
1672B5
2295A2
2295A5
2290A2
2290A5
6545
6459

**Mounting Accessories**

- Tubular socket wrench
- Extraction tool

<b>Type</b>
1383
1362A

**Set of accessories Type 1300A81 consisting of: Art. No.**

- Step drill, diameter 7,2/3,85 mm
- Countersink
- Twist drill, diameter 10 mm
- Reamer, diameter 4 H7
- Tap M8 x 0,75
- Finishing tool
- Hexagonal socket wrench
- Lapping tool
- Limit plug gage, diameter 4 H7
- Checking tool
- Clamp
- Fork wrench SW4/SW5

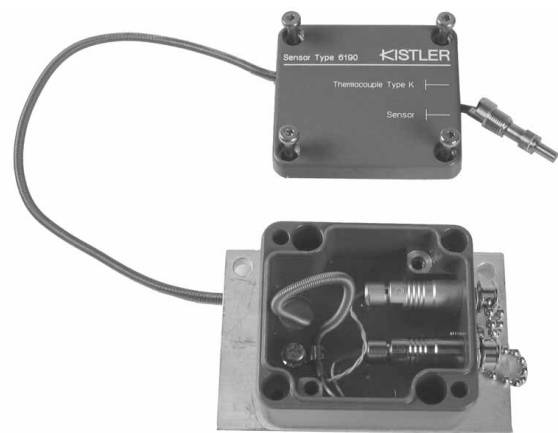

Fig. 8: Shortening the cable

6190A\_000-039e-10.04