

CoMo Logic®

Type 5875A...

Single-Channel y(t) ControlMonitor

The CoMo Logic monitor has a graphics display and charge mode input for monitoring time-dependent measurands in production processes. It is particularly suitable for monitoring force/time characteristics of manual and automated assembly and test processes.

- LC graphics display 128x128 pixel
- Desktop case, 19" cassette or panel mount
- Measuring ranges FS $\pm 50 \dots \pm 500\,000$ pC
- 10 kHz sampling rate
- 3 real-time thresholds
- Graphic with y(t) signal characteristics
- Graphic showing trend exhibited by the last 118 cycle peaks
- Numerical display of the peak of the cycle
- Numerical display of the actual value
- Monitor output ± 10 V
- Memory for 8 sets of parameters
- 6 digital inputs
- 4 digital outputs
- Monitoring of up to 1 000 cycles per minute
- RS-232C interface
- PC configuration software
- PC flashloader

Description

The CoMo Logic is a y(t) ControlMonitor with three real-time thresholds and elementary post-cycle curve analysis function. The following operating modes are available: 'GRAPHIC' for displaying the y(t) signal characteristics, 'TREND' for displaying the last 118 peaks of the cycle and 'PEAK' with numerical display of the cycle peak.

The 'INSTANT' mode is provided for installation and adjustment. This displays the actual value and the peak continuously, and allows the 'SENSITIVITY' to be adjusted during measurement.

It can be operated with the front panel controls or with a PLC via the digital I/O. An analog monitor output with the scaled sensor signal is available for external data acquisition. Eight sets of parameters make it easier to change over between different operating modes and applications.



In a typical installation a high impedance, charge mode force or strain sensor provides signal input. Four versions of the unit accept charge mode inputs in ranges of $\pm 5\,000$ pC ... $\pm 500\,000$ pC.

Design

The CoMo Logic monitor consists of a measuring and a display unit, each controlled by a microprocessor.

The measuring unit (monitor) scales the sensor signal and monitors the signal characteristics at a sampling rate of 10 kHz. Whenever defined real-time events, such as thresholds being exceeded, occur in the cycle, the associated digital outputs are set immediately.

After the cycle the curve is analyzed and the digital outputs assigned to the corresponding post-cycle events are set. The measured values are then transferred to the display unit (graphic controller), which displays them in graphical or numerical form depending on the selected mode. A memory with 480 measurements is available for displaying the y(t) signal characteristics.

Technical Data

Signal Input (Sensor)

FS measuring range		
Type 5875Ax11	pC	±50 ... ±5 000
Type 5875Ax12	pC	±500 ... ±50 000
Type 5875Ax13	pC	±1 000 ... ±100 000
Type 5875Ax14	pC	±5 000 ... ±500 000
Error	%	<±1
Input filter, passive		
with 10 m coaxial cable	kHz	≈20
Connection		BNC neg.

Signal Processing

Frequency range (-3 dB)	kHz	≈0 ... >4
Drift at		
25 °C	pC/s	<0,1
50 °C	pC/s	<0,5
Reset/Measure transition	pC	<±1
Measure/Reset time		
(Residual charge <0,5 % FS)		
Range · Sensitivity		
<1 000 pC	ms	<6
≥1 000 pC	ms	≈5 + 1,5 · $\frac{\text{Range} \cdot \text{Sensitivity}}{1\,000\text{ pC}}$
Input voltage, continuous	V	<±10
Sampling rate	kHz	10
Linearity error	%FS	<±0,1
Repeatability error	%	<±0,1
Analog/digital converter, unipolar		
switchable for -Q/+Q		
resolution (0 ... +100 %FS)	Bit	10
Voltage between		
signal GND and chassis ground	V _{rms}	<40
Monitor output		
Error	%	<±0,5
(excluding amplifier error)		

Digital Inputs

AC optocoupler, electrically isolated		
Logic level		
HIGH	V	>8
LOW	V	<2
Input current at 24 V	mA	3,3
Continuous input current	V	<±40
Voltage between		
inputs and chassis ground	V _{rms}	<40

Digital Outputs

Photoelectric MOS relay, electrically isolated		
Current load		
continuous	mA	<120
pulse <0,1 s	mA	<360
Max. resistance when switched on	Ω	<35 (typ. 23)
Voltage	V	<40
Voltage between		
outputs and chassis ground	V _{rms}	<40

RS-232C Interface

without control lines, level in accordance with standard, electrically isolated		
Baud rate	bps	19 200
Data format		
data bits, stop bit, parity		8, 1, none
Voltage at receiver input, continuous	V	<±20
Voltage between		
GND and chassis ground	V _{rms}	<40

General

LCD graphics display with		
backlighting	pixels	128x128
Memory depth (measurements per cycle)		480
Set of parameters		8
Operating temperature range	°C	0 ... 50
Power supply	VDC	18 ... 30
Power consumption	W	<4
Voltage between supply terminals		
and chassis ground	V _{rms}	<40
Dimensions		
Desktop case (WxHxD)	mm	105x146x193
19" cassette DIN41949, part 5	HE/TE	3/14
Depth	mm	170
Weight	kg	≈1,1
Degree of protection	EN60529	IP40
Power adapter	Type	5779A1
Input		
	VAC	90 ... 264
	Hz	48 ... 62
Output		
	VDC	24
	W	10
	A	<0,4

The monitor complies with the EMC provisions of EN61000-6-3 (interference) and EN61000-6-2 (immunity).
The power adapter complies with the safety requirements of EN60950.

Dimensions

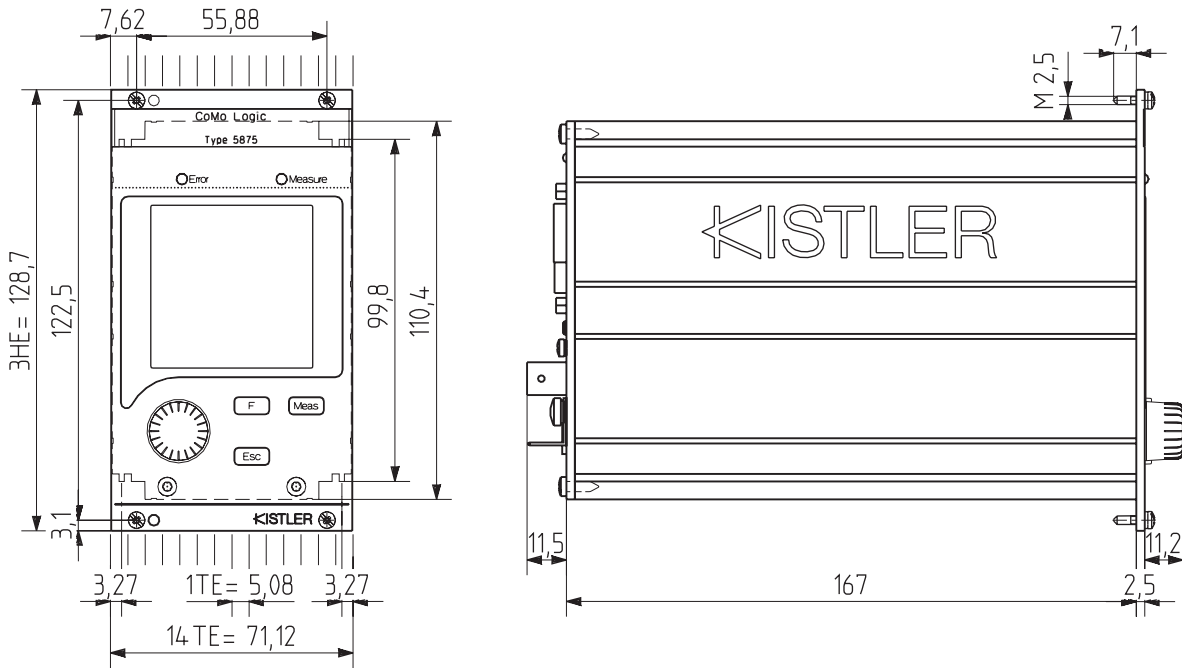

Fig. 1: 19" cassette DIN41949, part 5 for rack mounting Type 5875A0xx

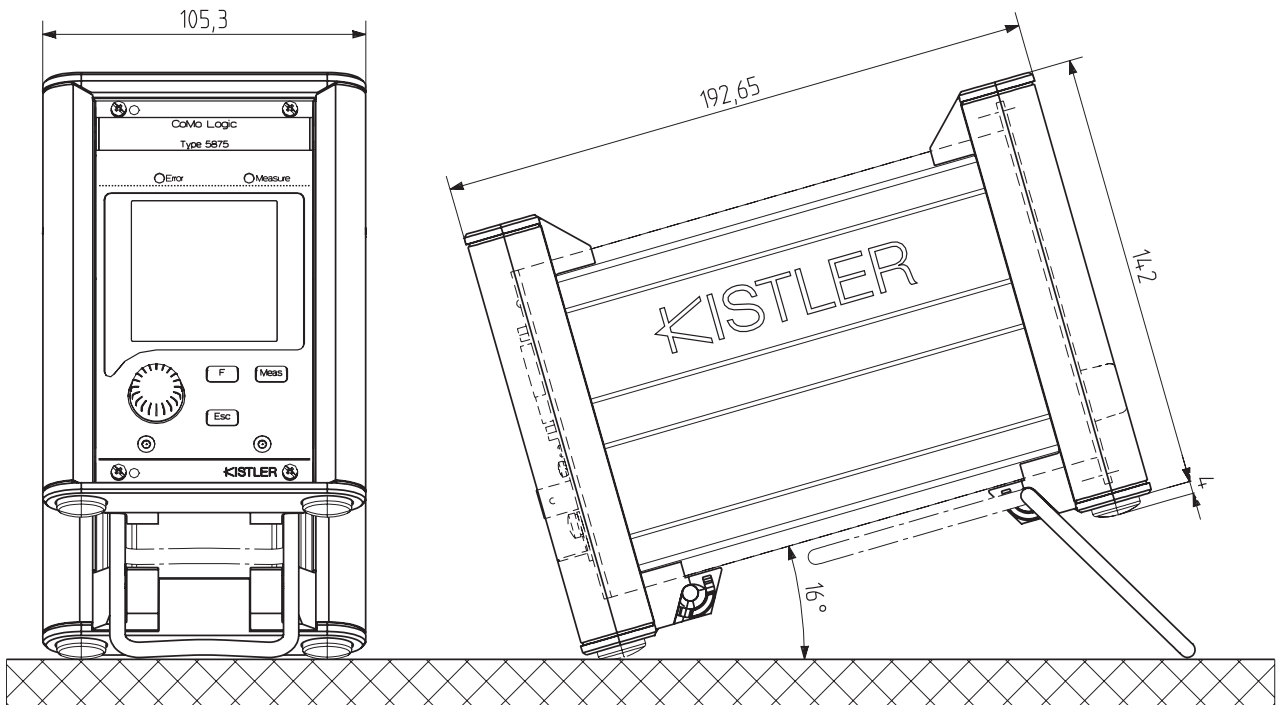

Fig. 2: Desktop case with support bracket, Type 5875A1xx (stackable)

5875A_000-492e-10.05

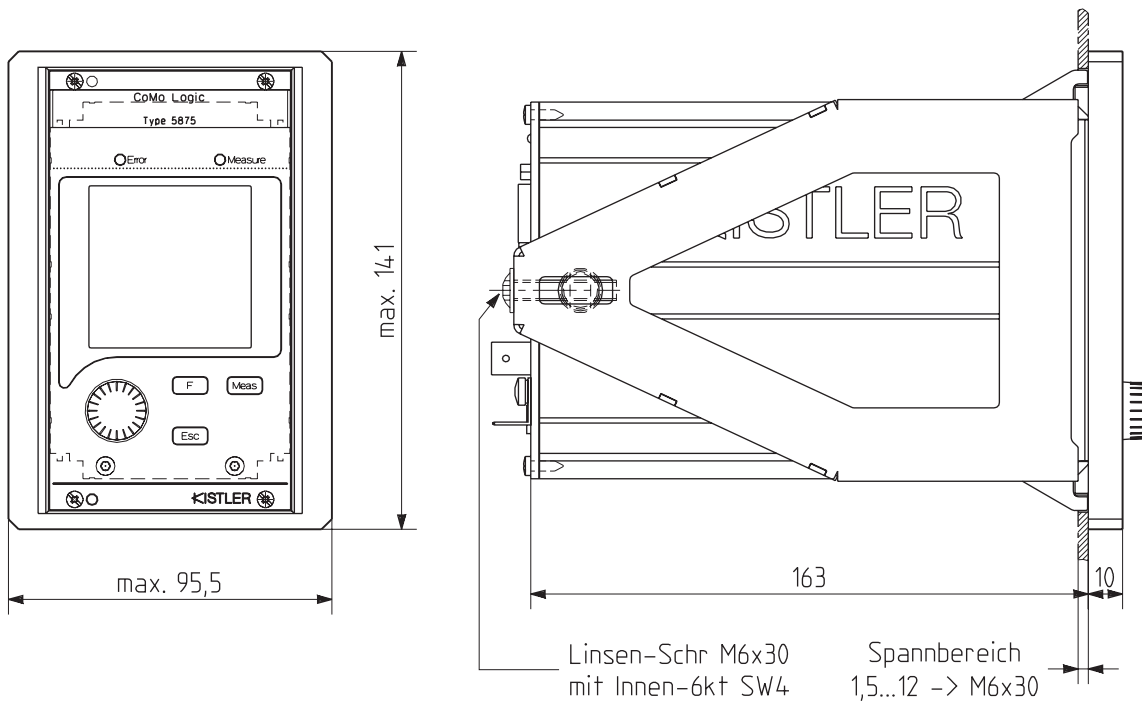

Fig. 3: 19" cassette DIN41949, part 5 for rack mounting with panel mounting set, Type 5875A2xx

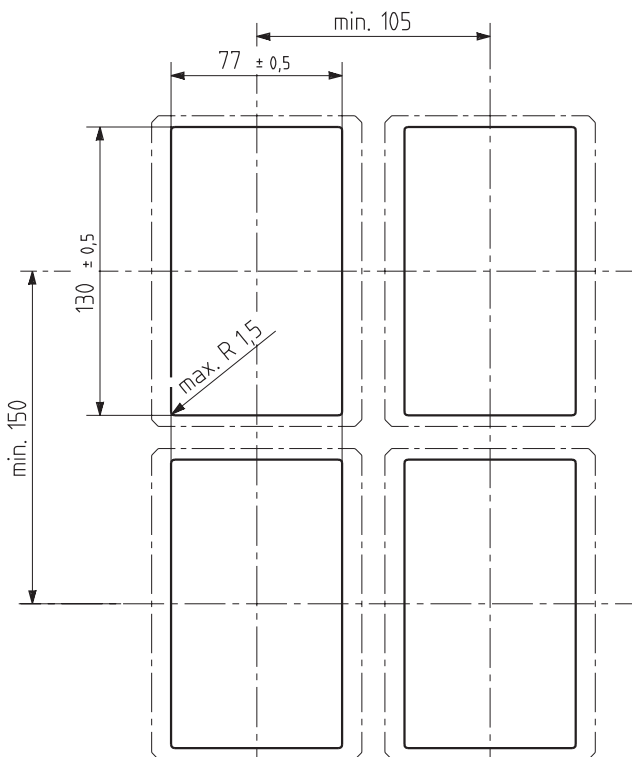

Fig. 4: Cutout dimension

Note

The 19" cassette Type 5875A0xx cannot be retrofitted for panel mounting. Type 5875A2xx with panel mounting set is a separate version which must be ordered as such in the first place.

5875A_000-492e-10.05

5875A_000-492e-10.05

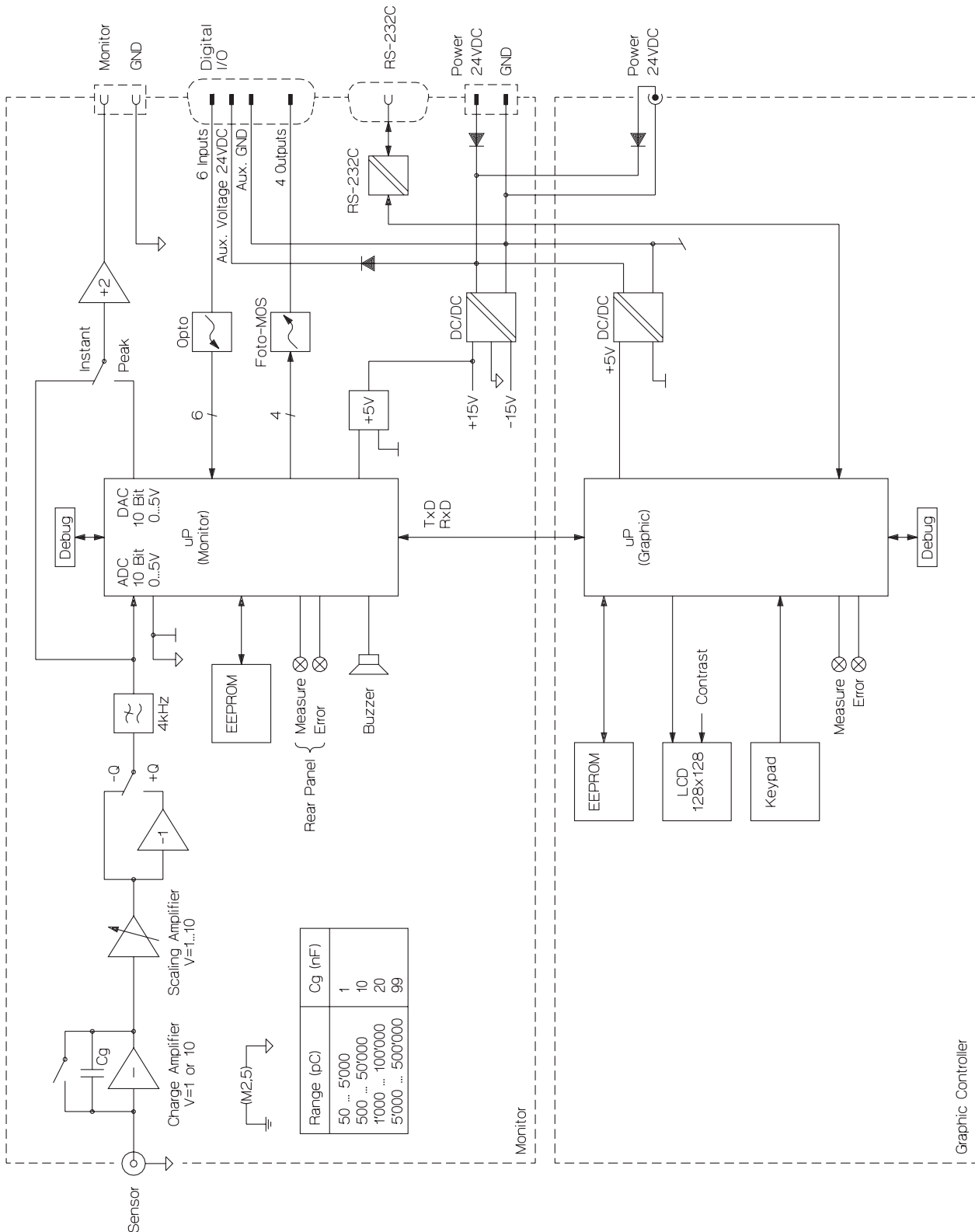

Fig. 5: Block schematic diagram of Type 5875A...

Operation

All settings are made using the menus. The main menu is displayed by pressing the [F] button. Certain parameters (shaded grey in Figure 6) depending on the 'MODE' can be chosen and set using the menu or directly with the cursor.

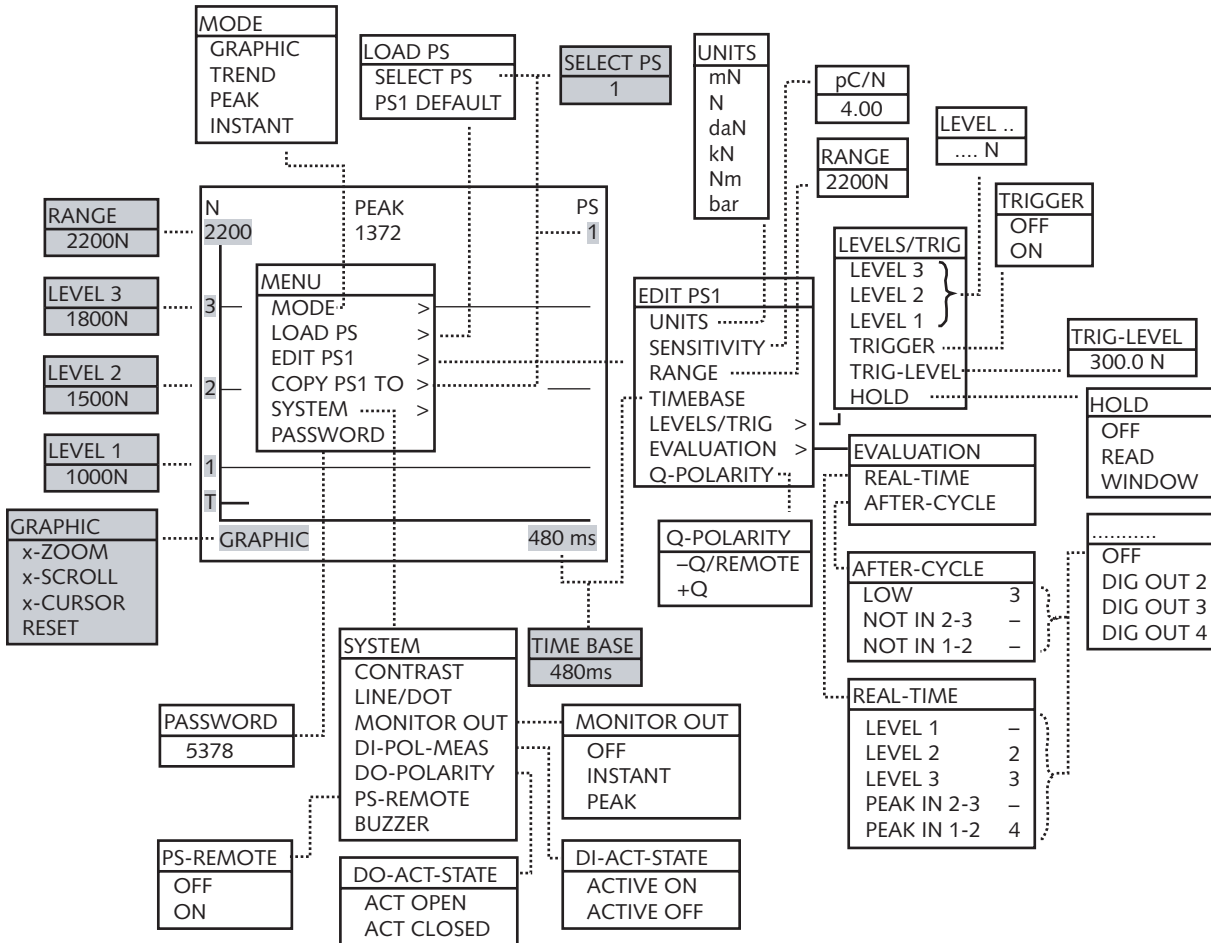

Fig. 6: Menu system

Controls



- ROTATION: Turn the knob to navigate the cursor within the menu system and set values
- PRESSING: Push the knob to choose menu commands and enter values



- Main menu



- Return to the next higher menu level **WITHOUT** saving changes.
- Clear current display.



- Measure/Reset for manual measurement.

Password

A number between 1 and 65535 is used as password. The main menu may only be accessed after entering the password. 0 switches the password off.

Contrast

Contrast can be reset to an average value if the [F] button is being pressed when switching on the monitor and kept depressed until the error LED stops blinking.

ERROR MESSAGES

LEVEL/RANGE	Value invalid as does not meet following condition: $RANGE \geq L3 \geq L2 \geq L1$
NO HOLD	No signal at digital input 3 Hold
OVERLOAD	Sensor signal > SENSITIVITY · RANGE
RS-232C	Communication error
SYSTEM	System error

5875A_000-492e-10.05

Operating Modes 'MODE'

Grey shaded fields can be selected directly with the cursor.

Operating Mode 'GRAPHIC'

The y(t) signal characteristics, real-time thresholds 1 to 3, the trigger threshold and the PEAK are displayed. The time axis is determined with the 'TIME BASE' setting (48 ms ... 60 s).

Additional functions are available on the 'GRAPHIC' menu. 'x-ZOOM' allows the signal characteristics to be spread by a factor of up to 4 and 'x-SCROLL' allows the curve to be moved along the time axis. 'x-CURSOR' displays a cursor that can be moved along the time axis as well as the associated measurement and its time. RESET restores the graphic default setting.

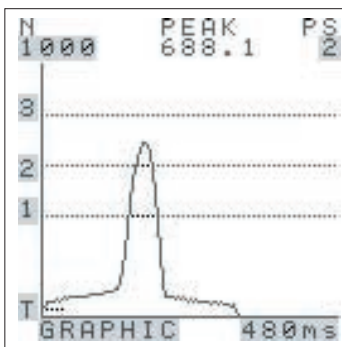

Operating Mode 'TREND'

A graphic showing the trend exhibited by the last 118 cycles is displayed. The PEAK of the current cycle and the number of cycles are also shown (bottom right).

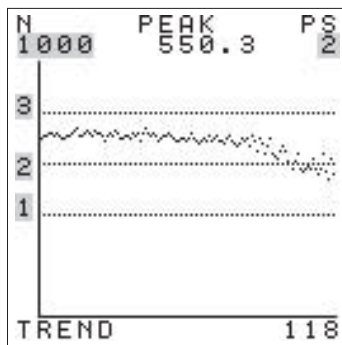

Operating Mode 'PEAK'

The PEAK (drag indicator) of the current cycle and the number of cycles are displayed. The ^ sign indicates that the corresponding real-time threshold has been reached.

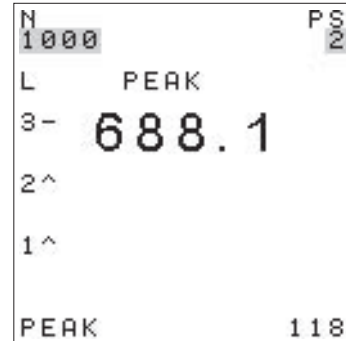

Operating Mode 'INSTANT'

This mode without event monitoring is used for installation and adjustment. The actual value and the peak (drag indicator) of the current cycle are displayed.

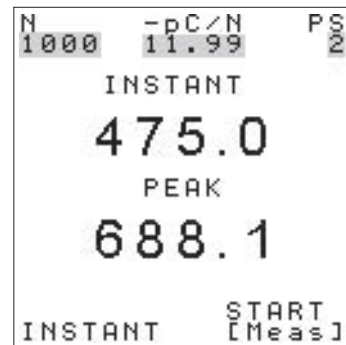

The measuring chain can be adjusted by opening the sensitivity window prior to the start of the measurement. This way 'SENSITIVITY' ① can be altered during a measurement and the resulting measured value ② is indicated instantly. Pressing the knob saves the new sensitivity.

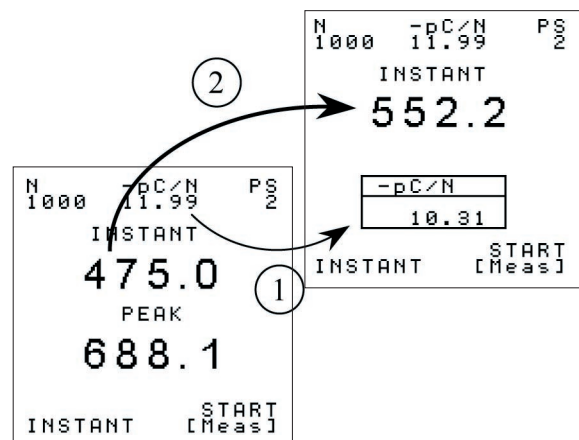

5875A_000-492e-10.05

Signal Input

Charge (Q), default setting for 'Q-POLARITY' is negative (-Q).

Signal Analysis

Basically only signals that are always positive or always negative can be acquired and analyzed. Signals that pass through zero during the cycle, e.g. when a compression force changes to a tension force, can only be evaluated if the sign is changed via digital input 2 Polarity at this point.

Monitor Output

The monitor output delivers the sensor signal scaled to ±10 V for the selected range 'RANGE' and mechanical unit 'UNIT'. The behaviour of the monitor output depends on the setting 'MONITOR OUT' as follows:

- 'OFF' Monitor output switched off.
- 'INSTANT' Current sensor signal, selected range scaled to ±10 V.
- 'PEAK' At cycle end a voltage is set corresponding to the cycle peak value and kept until the next cycle start. Peak definition depends the same way on the setting of the parameter HOLD as the evaluation of peak in-events does.

Digital Inputs

One digital input is available for Measure, one for the polarity of the sensor signal and one for Hold. Three others allow a set of parameters to be chosen (binary coded).

The Measure digital input can be defined on the DI-ACT-STATE menu as 'ACTIVE ON' or 'ACTIVE OFF' (no current). If Measure is defined as 'ACTIVE OFF', and when the monitor is switched on and digital input 1 (pin 2) is open, a measuring cycle is started. This can be terminated with the MEAS button. At the same time Measure is reset to ACTIVE ON. All other digital inputs are permanently ACTIVE ON.

Digital Outputs

In addition to an output for Device Ready, there are three configurable outputs available, to which eight events per set of parameters can be assigned. One output can be assigned to several events at the same time (logical OR).

On the DO-ACT-STATE menu the digital outputs can be defined collectively as 'ACT OPEN' or 'ACT CLOSED'. The one exception is the Ready output, which for safety reasons (power failure) is permanently defined as ACT CLOSED.

Timing Diagram

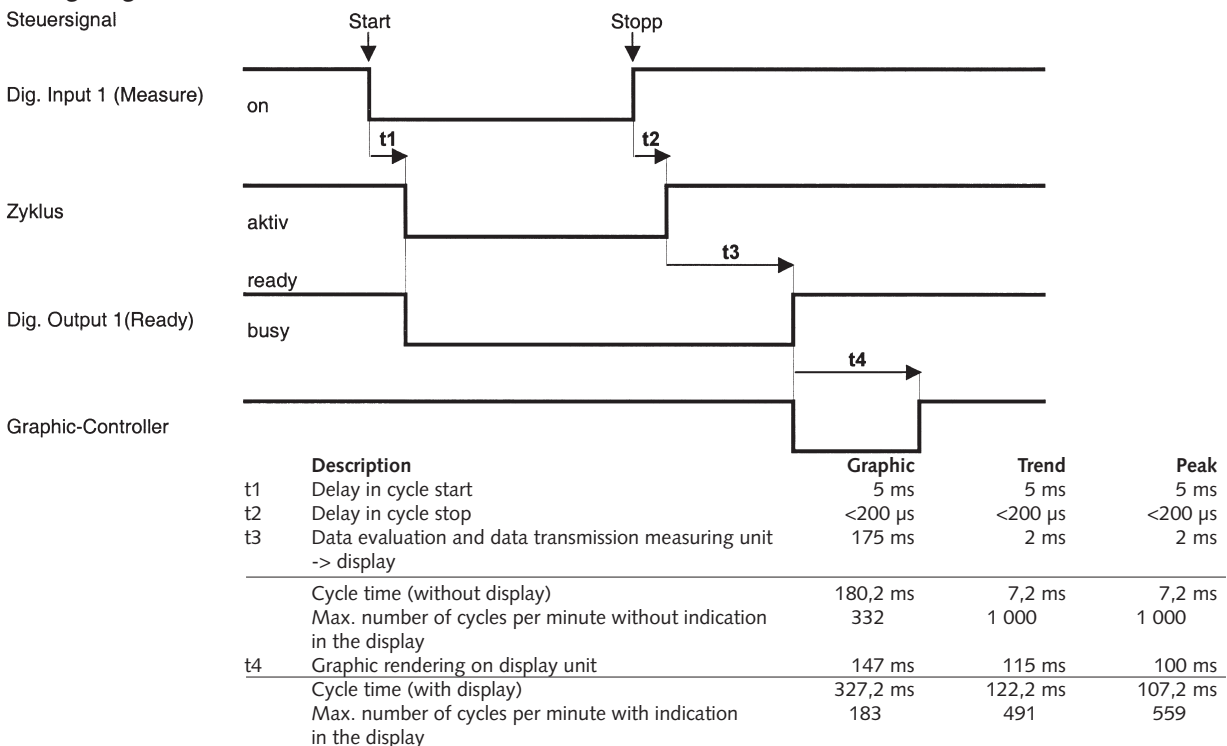

5875A_000-492e-10.05

Real-Time Events

During the cycle the events appear immediately at the digital outputs (maximum delay 1,2 ms):

Event	Condition
Level x	Value \geq Level x
Peak in x-y	Max. in [Level x, Level y] AND Value $<$ max. - 6 %FS (Hysteresis 0,23 %FS)

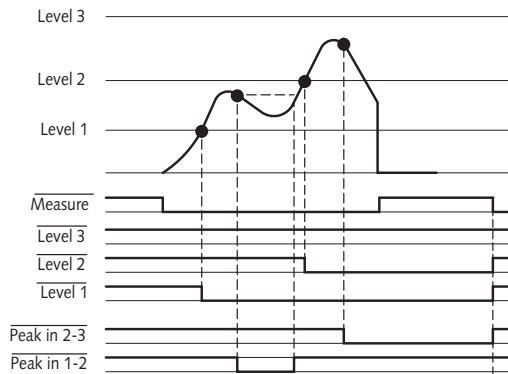

Fig. 7: Real-time events

Level Events

The changes in status caused by level events at the corresponding digital output are retained until the next start of the cycle, even if the measured value drops below a certain threshold in the course of the cycle.

Peak in Events

Peak in events are used to detect peaks. The changes in status caused at the corresponding digital output are retained until the next start of the cycle. The 'HOLD' setting is particularly important here:

'OFF' A peak is detected if the measured value drops more than 6%FS below the peak. An event is retained for as long as the measured value does not rise above this value (peak - 6%FS) again.

'READ' No peak detection. A Peak in event only indicates that the measured value was between the corresponding levels at the time of the flank of Hold.

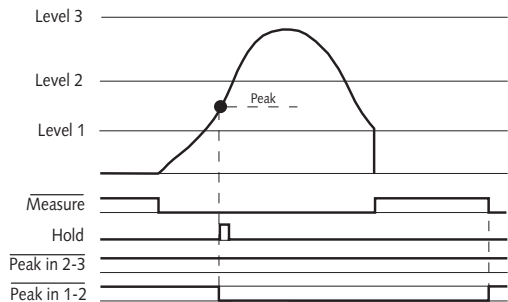

Fig. 8: Hold Read

'WINDOW' Same behaviour as described for OFF, limited to the duration of the window. If no peak by definition is detected in the window, the maximum value is taken and the peak in-event is set accordingly.

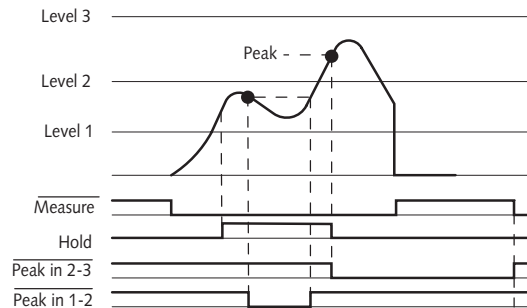

Fig. 9: Hold Window

Post-Cycle Events

The events are set after measurement (max. delay 1,2 ms) if the peak satisfies one of the following conditions:

Event	Condition
Low	Peak $<$ Level 1

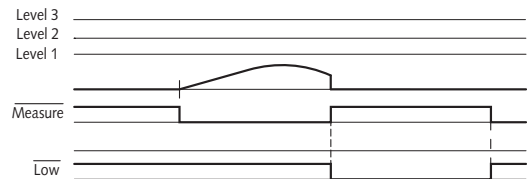

Fig. 10: Post-cycle event low

Event	Condition
Not in x-y	Peak not in [Level x, Level y]

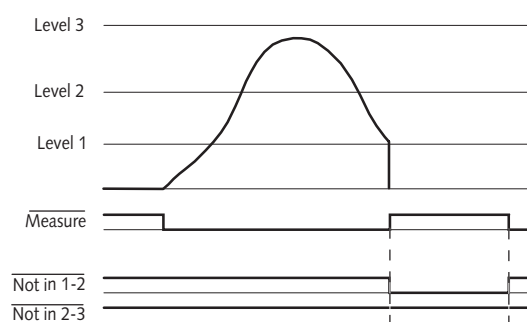

Fig. 11: Post-cycle event Not in

Post-cycle events can be indicated acoustically by means of a 'BUZZER'.

5875A_000-492e-10.05

Power

2,5 mm DC socket
or 3,5 mm Phoenix

Function		Pin
Power	24 VDC	1 (+)
Power	GND	2 (-)

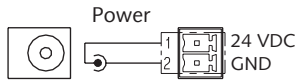

Note

The polarity protection diodes prevent the unused connection being used to supply external functions.

Digital I/O

D-Sub-15 male

Function		Pin
Input 1	(Measure)	2
Input 2	(Polarity)	3
Input 3	(Hold)	10
Input 4	(Param Bit2 ⁰)	1
Input 5	(Param Bit2 ¹)	9
Input 6	(Param Bit2 ²)	4
Common	Input 1 ... 6	11
Output 1	(Ready)	14
Output 2		6
Output 3		13
Output 4		5
Common	Output 1 ... 4	7
Aux. Voltage	24 VDC	15
Aux. Voltage	GND	8
N.C.		12

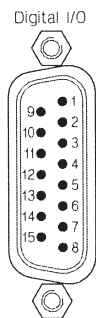

RS-232C

Function	Pin
RxD	2
TxD	3
GND RS	5

D-Sub-9S female

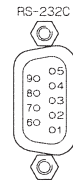

Interface parameters

19 200 baud, 8 data bits,
1 stop bit, no parity, no flow control

Back View

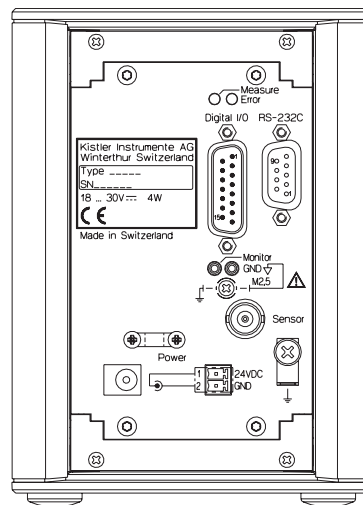

Fig. 12: Back of CoMo Logic Type 5875A1xx

Accessories Included

CoMo Logic Type 5875A... with

- Phoenix terminal for 24 V supply, 2-pole 7.640.072
- Cable connector D-Sub-15 female for digital I/O 7.640.063
- Test cable black, for 2 mm sockets, for monitor output 5.590.096
- Test cable red, for 2 mm sockets, for monitor output 5.590.097
- PC configuration software and PC Flashloader 7.643.022

Type/Art. No.

CoMo Logic Type 5875A1... additionally with

- Power line adapter 90 ... 264 VAC/24 VDC with DC connector 5779A1

Optional Accessories

- RS-232C null modem cable, l = 5 m, D-Sub-9 male/female 1200A27
- Connecting cable for monitor output, 2 x 2 mm connector – BNC pos. 1700A57
- Converter USB 1.1 to RS-232C D-Sub-9, male, USB 1.1 2867

Type/Art. No.

Ordering Key

Type 5875A

19" cassette DIN41494 part 5, for rack mounting, 14 width units and 3 height units, without power adapter	0
Desktop unit with stand and power adapter, 90 ... 264 VAC	1
19" cassette DIN41494 part 5, for rack mounting, 14 width units and 3 height units, with panel mounting set, without power adapter	2

Measuring range ±50 ... ±5 000 pC	11
Measuring range ±500 ... ±50 000 pC	12
Measuring range ±1 000 ... ±100 000 pC	13
Measuring range ±5 000 ... ±500 000 pC	14

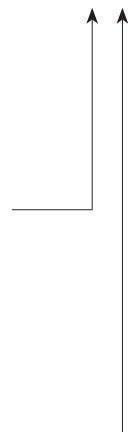

5875A_000-492e-10.05