

K-Beam® Power Supply

Type 5210

Capacitive Accelerometer Power Supply

A convenient, simple to use power supply that provides an interface between capacitive accelerometers and measuring instruments.

A single channel unit powered by an internal 9 volt battery or an AC/DC adaptor.

- For K-Beam accelerometers
- Adjustable offset control for higher resolution measurements
- Battery or external power
- Gain and filtering options; low battery indicator
- Complete kit available
- Conforming to CE



Description

The 5210 power supply is a single channel power supply intended for the K-Beam line of capacitive accelerometers. The unit is a low cost and convenient way to power a Kistler capacitive accelerometer from a casual check to an in-depth study. A key feature of this instrument is its ability to adjust the output voltage offset so that $0g = 0$ volts therefore read-out equipment can be set to lower ranges for viewing measurements at higher resolution. The unit may be powered by a standard 9V battery, external DC supply, or AC powered with an appropriate wall adaptor. Internal circuitry permits selectable gain from 1X to 20X. Signal filtering is available from optional low pass, plug-in filters designed to reduce high frequency signals. LEDs are used to indicate power mode and condition. A green indication shows external powering and red indicates a low battery condition. A high capacity external battery can be connected when field studies require long-term monitoring. Kistler recommends using an optional 1592A (2 meter) cable or 1592AspX (X=length) for connecting the 5210 to K-Beam sensors such as 8305AM4, 8310A or 8312A. The power supply is housed in a rugged plastic case. A kit version includes the 5210 power supply, AC-DC power adaptor, and carrying case.

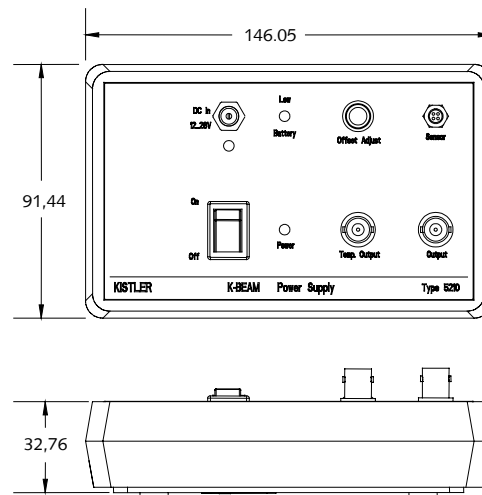

Application

The primary use for the 5210A is to provide excitation power and signal tailoring for capacitive accelerometer types 8305A, 8310A and 8312A. It is a low cost unit that provides excellent portability to a vibration measurement system both in the laboratory or in the field.

000-334e-04.04 (K12.5210)

Technical Data

Type	Units	5210
Input Information:		
Signal	V	±5
Sensor Excitation Voltage, nom.	V	9
Current, max.	mA	25
Output Information:		
Signal max.	V	±8
Impedance	Ω	100
Signal Processing Gain standard		
Jumper, selectable		1, 10, 20
Accuracy (gain dependent)	%	±0,5 ... ±1,5
Upper Frequency Limit -5% (w/o filter)	Hz	750 ±50
Noise Contribution to meas. chain	μV Hz	1
Noise, Wide Band (gain 1:1 w/o sensor)	μV _{rms}	300
Offset Adjust Range (gain dependent)	V	±1,8 ... ±3,6
Output @ Zero g standard	V	0
Jumper, selectable	V	+2,5
General Information:		
Temperature Range Operating	°C	-9 ... 54
Temperature Range Storage	°C	-20 ... 60
External DC Voltage Source	V mA	12...28 <50
Battery Life with sensor 8305A	hr	24
with sensor 8304B	hr	10
Low Battery Time	min	30
Internal Battery type IEC 6LR61	type	9V alkaline
Connectors Sensor	type	Microtech 4-pin pos.
Output:		
signal	type	BNC neg.
External DC input	type	2,1mm jack (tip+)
IP Rating		40
Case Dimensions :		
W	mm	146,05
H	mm	91,44
D	mm	32,76
Weight (including battery)	grams	260

1 g = 9,80665 m/s², 1 inch = 25,4 mm, 1 gram = 0,03527 oz, 1 lbf-in = 0,1129 Nm

Mounting

The 5210A is a single unit capacitive accelerometer power supply and signal conditioner housed in a plastic case. It is primarily intended for laboratory bench top use and should be protected if carried into an industrial environment.

Ordering Information

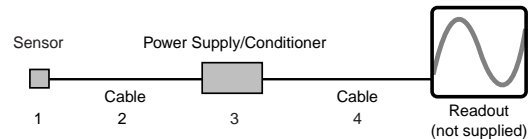

sp = specify cable length in meters

- 1 - 8305A ... M4 K-Beam low profile, ground isolated accelerometer
- 8305A ... M7 K-Beam low profile, ground isolated accelerometer, with 2 meter integral cable for connecting directly to a 5210
- 8310A ... K-Beam hermetically sealed, ground isolated accelerometer
- 8312A ... K-Beam light weight, ground isolated accelerometer
- 2 - 1592A(X) connecting cable, 4-pin Microtech neg. to 4-pin Microtech neg., required for and 8305A ... M4, 8310A ... , 8312 ... x = 2 or 4 meters
- 1592Asp connecting cable, 4-pin Microtech neg. to 4-pin Microtech neg.,
- 3 - 5210... K-Beam power supply (see ordering key)
- 4 - 1511sp output cable, BNC pos. to BNC pos.

Optional Accessories

- 5752 AC-DC power adaptor (115V, 60Hz)
- 5757 AC-DC power adaptor (230V, 50Hz)
- 704-2068-001 external DC power cable (6 ft. with pigtails)
- 300-0092-002 9V alkaline battery
- 440-0540-001 shunt jumper (spare)
- 5326A20 low pass filter, 20Hz, -12dB/octave
- 5326A50 low pass filter, 50Hz, -12dB/octave
- 600-4156-001 carrying case

Ordering Key

Measuring Range	5210
w/ 9v battery	-
w/ 115V power adaptor and case	S1
w/ 230V power adaptor and case	S1E

000-334e-04.04 (K12.5210)